

BLOCK SERIES H1

LED LIGHTING FOR HAZARDOUS AREAS
FLOOD & HIGHBAY

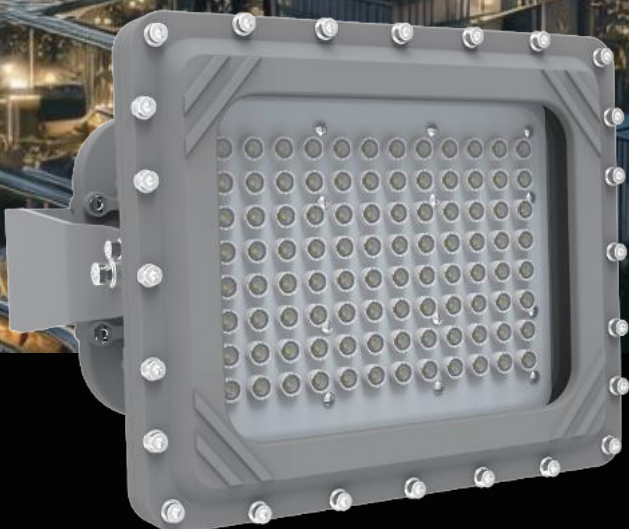

Reliable. Durable. Efficient.
12,000 to 21,000 lumen models

RED SKY
SERIOUSLY SAFE LIGHTS™

ABOUT RED SKY LIGHTING

PIONEERING INDUSTRIAL ILLUMINATION FOR HARSH & HAZARDOUS CONDITIONS

- A leading manufacturer of premium LED lights for demanding work conditions
- Headquartered in California, products assembled in the USA
- Servicing global clients across 4 continents in metal processing, oil & gas, marine, manufacturing
- Renowned for quality, dependability, client care and uncompromising safety standards

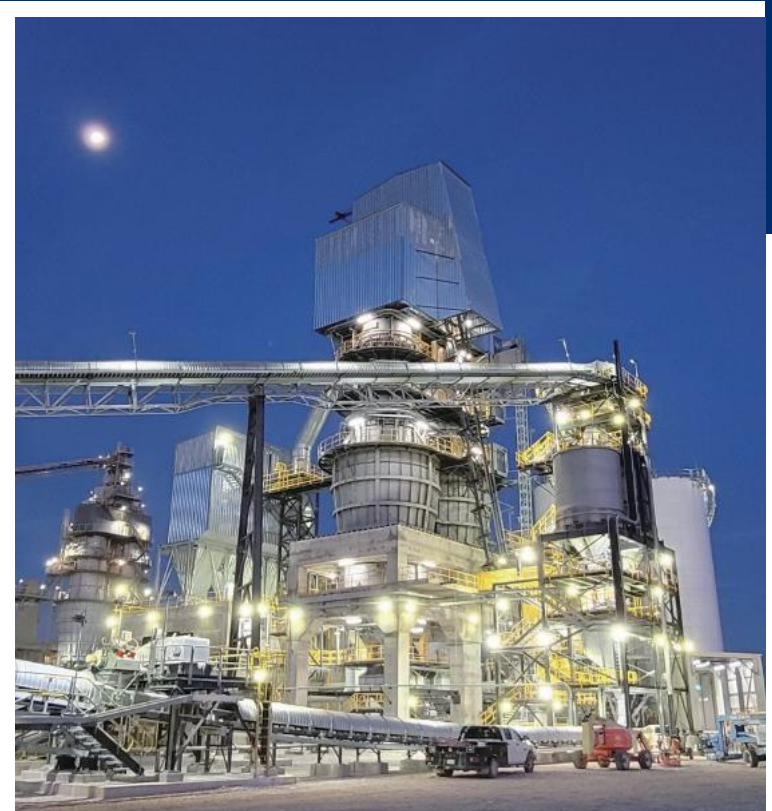

WHY CHOOSE RED SKY

❧ SERIOUSLY SAFE LIGHTS

- Rigorously tested in our professional labs
- Surpassing industry certifications and safety protocols
- Crafted with highest grade components for maximum durability

❧ TOP-NOTCH SERVICES

- Team of experts for seamless support
- Energy audit services, lighting simulation services
- Hassle-free return policy and management

❧ FAST DELIVERY

- Majority of orders delivered within 14 days
- Same day shipping for products in stock
- Real-time order tracking for full transparency

❧ SUSTAINABLE SOLUTIONS

- High luminous efficacy LEDs for energy savings
- Conscious product design
- Recyclable materials for products and packaging



BLOCK SERIES



Designed to withstand hazardous environments, the Block Series excels with a luminous efficacy of 146 lumens per watt. It is certified for use in hazardous locations requiring explosion-proof fixtures where flammable gases, vapors and combustible dusts are present. Applications include oil and gas rigs, petrochemical plants, and other hazardous corrosive facilities.

With 10kV built-in surge protection, the Block Series enhances safety and working conditions. Its dimmable driver helps reduce light pollution, enhance the working environment, and save on energy costs. Its self-contained LED and driver compartment, coupled with external cooling fins, ensures reliable heat dissipation even in extreme temperatures up to 140°F (60°C) while its robust design and quality enable operation under temperatures as low as -40°F (-40°C). The remarkable 121,000-hour LED fixture life at 140°F (60°C) guarantees long-term operation of the facility. A rugged copper-free aluminum body and frame provide superior corrosion resistance for long-lasting durability.

With three optic options ranging from spot to flood, the Block Series offers flexibility for a variety of applications. Red Sky Lighting backs the Block Series with an industry-leading 10-year warranty and factory replacement. Choose the Block Series for exceptional performance, advanced safety, and unmatched durability in hazardous industrial environments.



BLOCK SERIES
ILLINOIS, USA

FEATURES

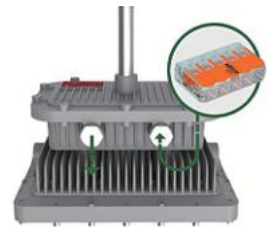

Excellent Heat Dissipation

Safe and reliable heat transfer - Offering a T-rating of T6 (CID1)
Self-contained LED and Driver compartment with external air-flow fins designed to perform in high ambient temperatures up to +140°F and as low as -40°F.

Rugged Construction

Built to withstand extreme temperatures, vibration, water and dust. Copper-free aluminum body and frame for corrosion-resistant.

Long Fixture Life

L70 >121,000 Hours@140°F

3 Optic Options

25° / 60° / 120° available for different applications from spot to flood for optimal light distribution.



25°

NEMA 3 - Narrow



60°

NEMA 4 - Medium



120°

NEMA 6 - Wide

RATINGS

Class I Division 1, Groups C, D	UL 1598 Wet Locations
Class I Division 2, Groups A, B, C, D	UL 1598A Marine Outside Type (Salt Water)
Class II Division 2, Groups F, G	IP66
Class III	IK09
Class I, Zone 1, Group IIB	Salt Spray 720 hrs (ASTM B117)
Class I, Zone 2, Group IIC	NEMA 4X
Zone 22, Group IIIB	

CERTIFICATIONS

UL844
UL1598
UL1598A
CSA C22.2 NO. 250.0
CSA C22.2 No. 137
DLC Standard*
FCC Part 15, Subpart B

* Not all product variations listed on this page are DLC qualified. Visit www.designlights.org/search to confirm qualification.

TECHNICAL PARAMETERS

Specification	BLK2-H1-80	BLK2-H1-100	BLK2-H1-120	BLK2-H1-150
Electrical Parameters				
Power	80W	100W	120W	150W
Rated Input Current(100V AC)	0.740A	0.925A	1.111A	1.388A
Rated Input Current(277V AC)	0.320A	0.401A	0.481A	0.601A
Rated Input Current(347V AC)	0.256A	0.320A	0.384A	0.480A
Rated Input Current(480V AC)	0.185A	0.231A	0.277A	0.347A
Voltage/Frequency	100-277V AC, 347-480V AC 50/60Hz			
Power Factor	≥0.90			
THD	<20%			
L70	121,000 hrs@140°F			
Dimming	0-10V, Range 10-100%			
Surge Protection	10KV			
Supply Wire	12-18AWG, Rated 90°C			
Warranty	LEDs: 10 years, Driver: 7 years			
Optical Parameters				
Lumen Output*	11,777Lm	14,416Lm	17,416Lm	21,141Lm
Lumen Efficacy*	146Lm/W			
Available Beam Angle	25° / 60° / 120°			
Correlated Color Temperature (CCT)	3000K/4000K/5000K			
Color Rendering Index (CRI)	80 CRI			
Mechanical Parameters				
Housing Material	die-cast aluminum			
Hardware	Stainless steel 316			
Lens Material	Tempered Glass			
Mounting Options	Pendant, Yoke, Stanchion			
Product Weight	33.5lbs/15.2kg		33.7lbs/15.3kg	
Package Weight	35.6lbs/16.2kg		35.8lbs/16.3kg	
Cable Entry	(3) 3/4" NPT			
Product Dimensions(L×W×H)	12.9×10.7×8.4in (328×271×214mm)			
Package Dimensions(L×W×H)	15.1×13.9×10in (383×353×255mm)			
Environmental Parameters				
Vibration Resistance	1.5G (ANSI C136.31)			
Ambient Operating Temperature	-40°F ~ +140°F (-40°C ~ +60°C)			
T-Code Rating	C1D1 – T6, C1D2 – T4A, C2D2 – T4A			
EPA wind rating (FT2)	1.715 (Yoke), 1.735 (Stanchion)			

* Value calculated based on 5000K, 80 CRI and clear glass ,varies to different spec.
70 CRI & 90 CRI optional, DLC available with 70 CRI only.

ORDERING INFORMATION

EXAMPLE: BLK2-80-100-277-5K-120-H1-CG-GRY-PND

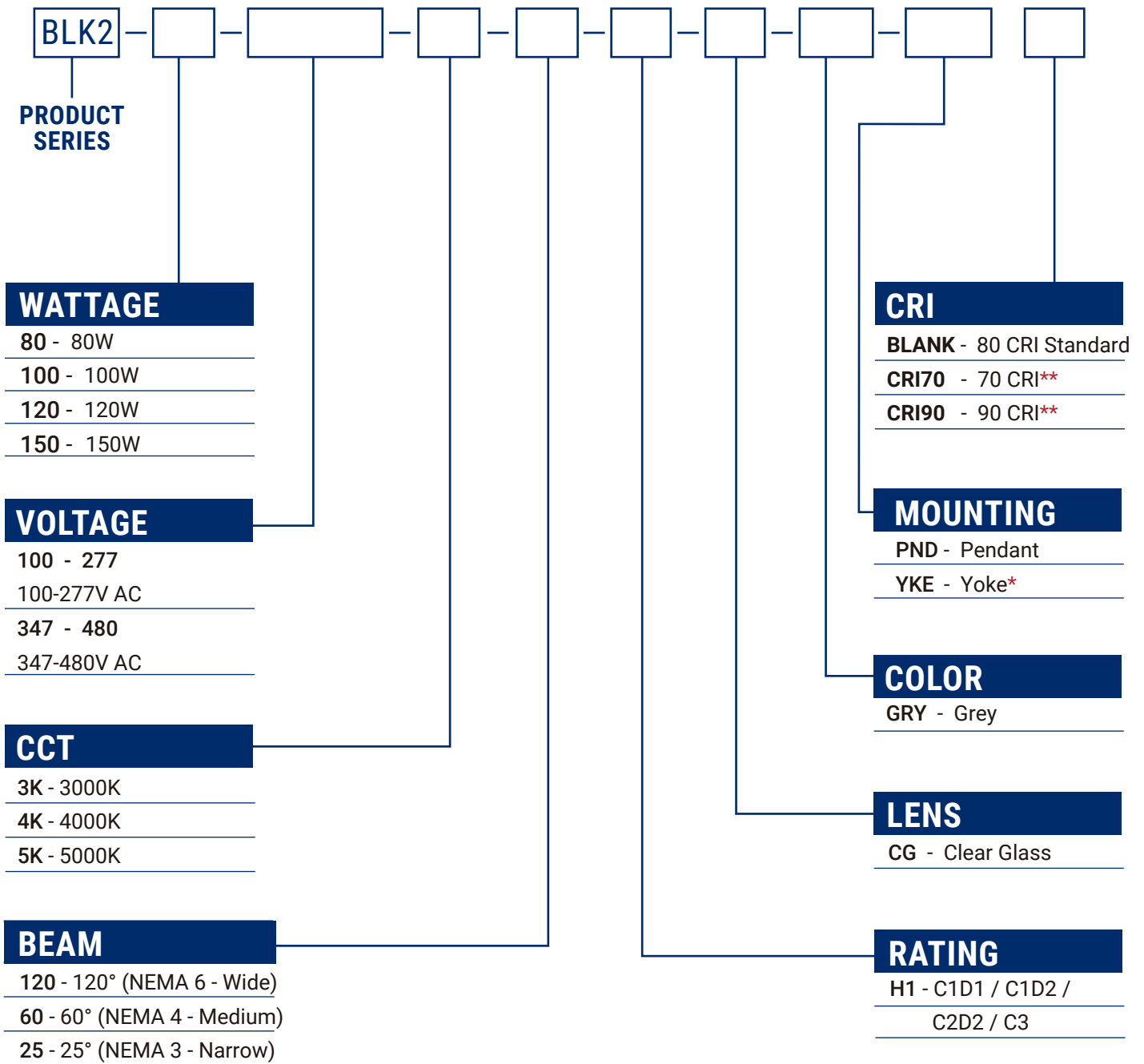

* BLK-YOKE pre-installed, contact sales for other Yoke options.

** CRI90 expects longer leadtime

DLC available with 70 CRI only. Not all product variations listed on this page are DLC qualified. Visit www.designlights.org/search to confirm qualification.

MOUNTING ACCESSORIES



Pendant



Yoke



Stanchion



BLK-YOKE



BLK-360Y



STAN01

Mounting Method	PN	Description	MPN Code
Yoke	BLK-YOKE	Yoke Mount SUS304, Powder-Coated Grey RAL 7037	210010013
	BLK-360Y	360-Degrees Rotation Yoke Mount, SUS304, Powder-Coated Grey RAL 7037	210010082
Stanchion	STAN01*	Slip-Fit Stanchion Mount Kit for Φ 2 inch (2-3/8 inch OD, 60mm OD) Poles, Non-Threaded, SUS304, Powder-Coated Grey RAL 703	210010031

* Requires A Yoke Mount

OTHER ACCESSORIES



SFCB01

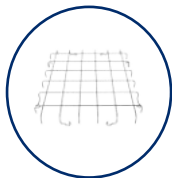

BLK-WG



BLK-VISO



HOOK02

PN	Description	MPN Code
SFCB01	Safety Cable Kit, SUS304	210010086
BLK-WG	Lens Wire Guard, SUS304	210010085
BLK-VISO	Visor, SUS304, Powder-Coated Grey RAL 7037	210010083
HOOK02	M10 Hook with 3/4 inch NPT Threads, SUS316	210010097

REPLACEMENT PARTS (ORDERED SEPARATELY)

Part Number	Description	MPN Code
BLK2-80-100-277-Driver	Replacement Driver Kit for BLK2-80-100-277 Fixtures	303010020
BLK2-100-100-277-Driver	Replacement Driver Kit for BLK2-100-100-277 Fixtures	303010021
BLK2-120-100-277-Driver	Replacement Driver Kit for BLK2-120-100-277 Fixtures	303010022
BLK2-150-100-277-Driver	Replacement Driver Kit for BLK2-150-100-277 Fixtures	303010023
BLK2-80-347-480-Driver	Replacement Driver Kit for BLK2-80-347-480 Fixtures	303010024
BLK2-100-347-480-Driver	Replacement Driver Kit for BLK2-100-347-480 Fixtures	303010025
BLK2-120-347-480-Driver	Replacement Driver Kit for BLK2-120-347-480 Fixtures	303010026
BLK2-150-347-480-Driver	Replacement Driver Kit for BLK2-150-347-480 Fixtures	303010027

LUMEN TABLE

PN	Wattage (W)	CCT	CRI	Beam	Lens	Lumen Output (Lm)	Efficiency (Lm/W)
----	-------------	-----	-----	------	------	-------------------	-------------------

Voltage 100-277VAC 80 CRI • STANDARD

BLK2-80-100-277-5K-120-H1-CG-GRY-YKE	80	5000K	80	120°	Clear Glass	11,777	146
BLK2-80-100-277-5K-60-H1-CG-GRY-YKE	80	5000K	80	60°	Clear Glass	11,114	138
BLK2-80-100-277-5K-25-H1-CG-GRY-YKE	80	5000K	80	25°	Clear Glass	11,671	145
BLK2-100-100-277-5K-120-H1-CG-GRY-YKE	100	5000K	80	120°	Clear Glass	14,416	143
BLK2-100-100-277-5K-60-H1-CG-GRY-YKE	100	5000K	80	60°	Clear Glass	13,485	134
BLK2-100-100-277-5K-25-H1-CG-GRY-YKE	100	5000K	80	25°	Clear Glass	14,145	140
BLK2-120-100-277-5K-120-H1-CG-GRY-YKE	120	5000K	80	120°	Clear Glass	17,416	145
BLK2-120-100-277-5K-60-H1-CG-GRY-YKE	120	5000K	80	60°	Clear Glass	16,211	135
BLK2-120-100-277-5K-25-H1-CG-GRY-YKE	120	5000K	80	25°	Clear Glass	16,846	140
BLK2-150-100-277-5K-120-H1-CG-GRY-YKE	150	5000K	80	120°	Clear Glass	21,141	142
BLK2-150-100-277-5K-60-H1-CG-GRY-YKE	150	5000K	80	60°	Clear Glass	19,470	129
BLK2-150-100-277-5K-25-H1-CG-GRY-YKE	150	5000K	80	25°	Clear Glass	20,200	136

Voltage 100-277VAC 70 CRI

BLK-80-100-277-5K-120-H1-CG-GRY-YKE CRI70	80	5000K	70	120°	Clear Glass	12,320	151
BLK-80-100-277-5K-60-H1-CG-GRY-YKE CRI70	80	5000K	70	60°	Clear Glass	11,180	136
BLK-80-100-277-5K-25-H1-CG-GRY-YKE CRI70	80	5000K	70	25°	Clear Glass	11,472	139
BLK-100-100-277-5K-120-H1-CG-GRY-YKE CRI70	100	5000K	70	120°	Clear Glass	14,162	148
BLK-100-100-277-5K-60-H1-CG-GRY-YKE CRI70	100	5000K	70	60°	Clear Glass	12,799	132
BLK-100-100-277-5K-25-H1-CG-GRY-YKE CRI70	100	5000K	70	25°	Clear Glass	13,275	136
BLK-120-100-277-5K-120-H1-CG-GRY-YKE CRI70	120	5000K	70	120°	Clear Glass	17,680	146
BLK-120-100-277-5K-60-H1-CG-GRY-YKE CRI70	120	5000K	70	60°	Clear Glass	16,497	132
BLK-120-100-277-5K-25-H1-CG-GRY-YKE CRI70	120	5000K	70	25°	Clear Glass	16,949	135
BLK-150-100-277-5K-120-H1-CG-GRY-YKE CRI70	150	5000K	70	120°	Clear Glass	21,227	147
BLK-150-100-277-5K-60-H1-CG-GRY-YKE CRI70	150	5000K	70	60°	Clear Glass	18,695	128
BLK-150-100-277-5K-25-H1-CG-GRY-YKE CRI70	150	5000K	70	25°	Clear Glass	19,393	132

Voltage 100-277VAC 90 CRI

BLK-80-100-277-5K-120-H1-CG-GRY-YKE CRI90	80	5000K	90	120°	Clear Glass	10,805	132
BLK-80-100-277-5K-60-H1-CG-GRY-YKE CRI90	80	5000K	90	60°	Clear Glass	9,805	119
BLK-80-100-277-5K-25-H1-CG-GRY-YKE CRI90	80	5000K	90	25°	Clear Glass	10,061	122
BLK-100-100-277-5K-120-H1-CG-GRY-YKE CRI90	100	5000K	90	120°	Clear Glass	12,420	130
BLK-100-100-277-5K-60-H1-CG-GRY-YKE CRI90	100	5000K	90	60°	Clear Glass	11,225	116
BLK-100-100-277-5K-25-H1-CG-GRY-YKE CRI90	100	5000K	90	25°	Clear Glass	11,642	119
BLK-120-100-277-5K-120-H1-CG-GRY-YKE CRI90	120	5000K	90	120°	Clear Glass	15,505	128
BLK-120-100-277-5K-60-H1-CG-GRY-YKE CRI90	120	5000K	90	60°	Clear Glass	14,468	116
BLK-120-100-277-5K-25-H1-CG-GRY-YKE CRI90	120	5000K	90	25°	Clear Glass	14,864	118
BLK-150-100-277-5K-120-H1-CG-GRY-YKE CRI90	150	5000K	90	120°	Clear Glass	18,616	129
BLK-150-100-277-5K-60-H1-CG-GRY-YKE CRI90	150	5000K	90	60°	Clear Glass	16,396	112
BLK-150-100-277-5K-25-H1-CG-GRY-YKE CRI90	150	5000K	90	25°	Clear Glass	17,008	116

347-480Vac models deliver the same lumen output as the 100-277Vac models.

This table lists only selected lumen packages. For additional model parameters, please contact our sales team.

Note: LXX# = nominal lumens. Verify lumen package before ordering.

LUMEN MAINTENANCE

Hours Ambient	0	15,000	30,000	45,000	60,000	75,000	90,000	100,000	150,000
25°C	100%	97%	94%	90%	87%	84%	81%	79%	70%
35°C	100%	97%	94%	90%	87%	84%	81%	79%	70%
45°C	100%	97%	93%	90%	86%	83%	80%	78%	69%
55°C	100%	97%	93%	89%	85%	81%	78%	76%	66%
60°C	100%	96%	92%	88%	84%	81%	77%	75%	64%

LUMINAIRE LIFESPAN

Ambient Temperature	Luminaire Lifespan (Hours)	Rated Service Life - Years (24/7 Operation)	Rated Service Life - Years (12/7 Operation)
25°C (+77°F)	100,000	11	23
35°C (+95°F)	100,000	11	23
45°C (+113°F)	100,000	11	23
55°C (+131°F)	49,000	6	11
60°C (+140°F)	34,000	4	8

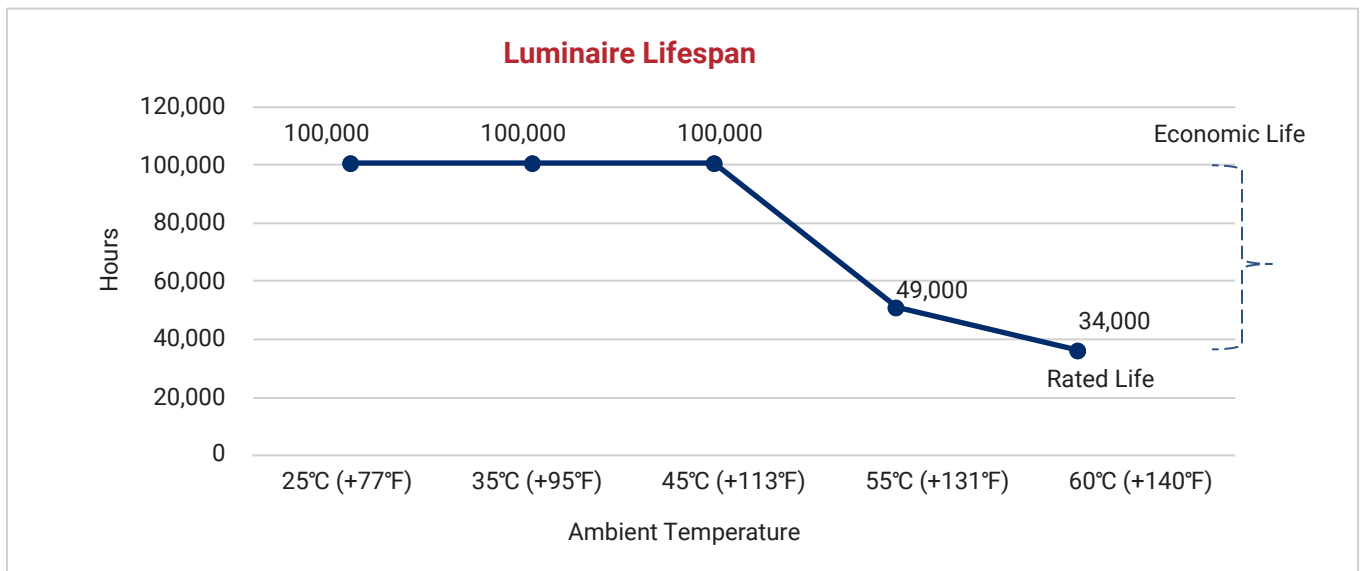

Information shown for reference only and may vary by configuration.

A DIRECT RETROFIT FROM HID TO LED

The BLK series LED is easy to retrofit in the same configuration as your existing HID luminaires. For example, a 150-watt Block (BLK2-150) delivers virtually the same illumination as its equivalent 450 watt Metal Halide luminaire while providing 80% reduction in energy costs and up to 148,000 hours of continuous operation.







MODELS	Lumen Output (Lm)	MH Equivalent (W)	HPS Equivalent (W)
BLK2-80	11,777	250	310
BLK2-100	14,416	320	360
BLK2-120	17,416	400	400
BLK2-150	21,141	450	400

THE RIGHT BEAM PATTERN FOR YOUR APPLICATION

RSL optic package is engineered to deliver maximum footcandles efficiently where you need them, without wasted light or overspill.

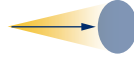
RSL offers complimentary lighting design services for our products using industry-leading AGI32 software, tailored for projects of all sizes in harsh and hazardous locations. We assist you in determining the number of fixtures needed, the types of lights to use, their optimal placement, and how to maximize energy savings—all within budget.

Simply fill out the form (<https://dev.redskylighting.com/lighting-design>) with a few key details, request a layout, and we'll bring your ideas to life within 2-5 business days.

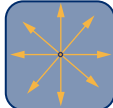
Beam	NEMA/IESNA Type	Beam Description	Beam Projection Distance
30°	NEMA 3	Medium Narrow	
60°	NEMA 4	Medium	
90°	NEMA 5	Medium Wide	
120°	NEMA 6	Wide	
T1	Type I	Asymmetric distributions, well suited for narrow areas, such as Conveyor belts, Aisleways, Catwalks, Loading docks and Tunnels.	
T2	Type II	Asymmetric distributions, well suited for narrow areas, such as roadways, paths and driveways.	
T3	Type III	Asymmetric distributions, well suited for site / area perimeters, wide roadways, and open areas.	
T5	NEMA 7 Type V (Square)	Very Wide: symmetrical pattern with excellent uniformity for large, open areas.	

PHOTOMETRIC

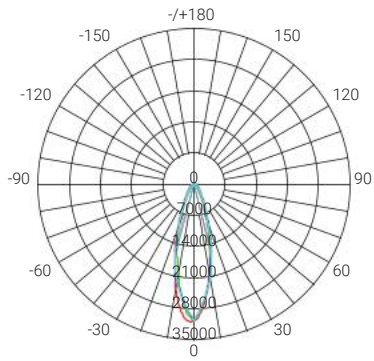

**25°
NEMA 3 - Narrow**

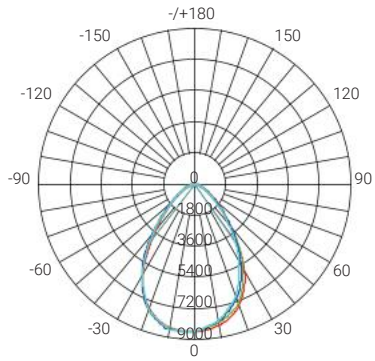

**60°
NEMA 4 - Medium**

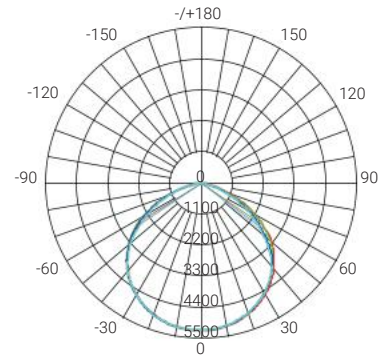

**120°
NEMA 6 - Wide**

DIMENSIONS

unit: in(mm)

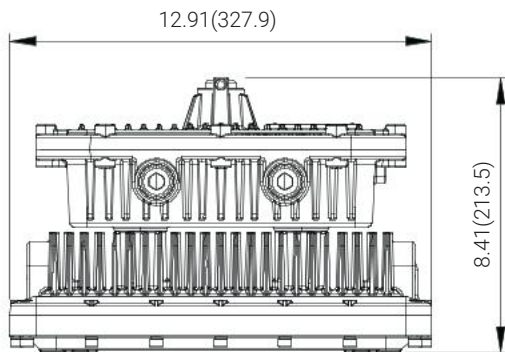

Pendant

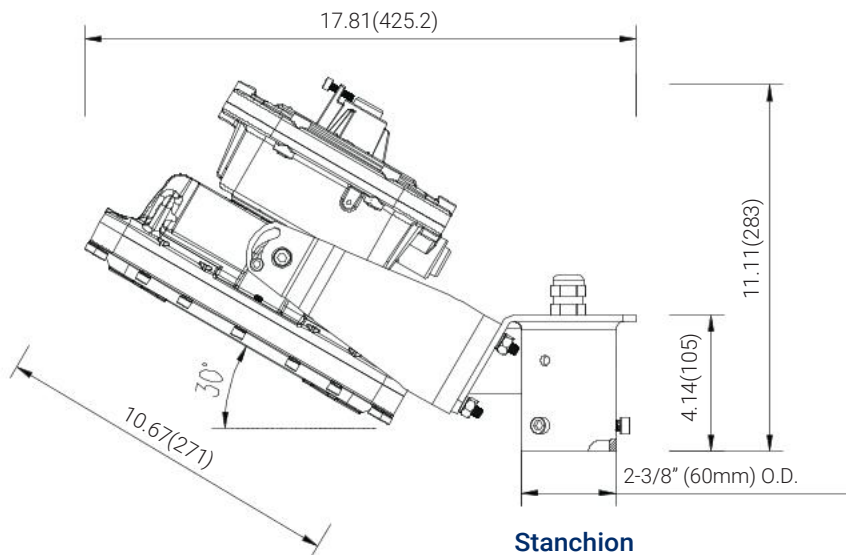
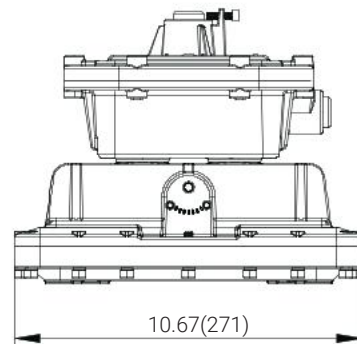

Stanchion

unit: in(mm)

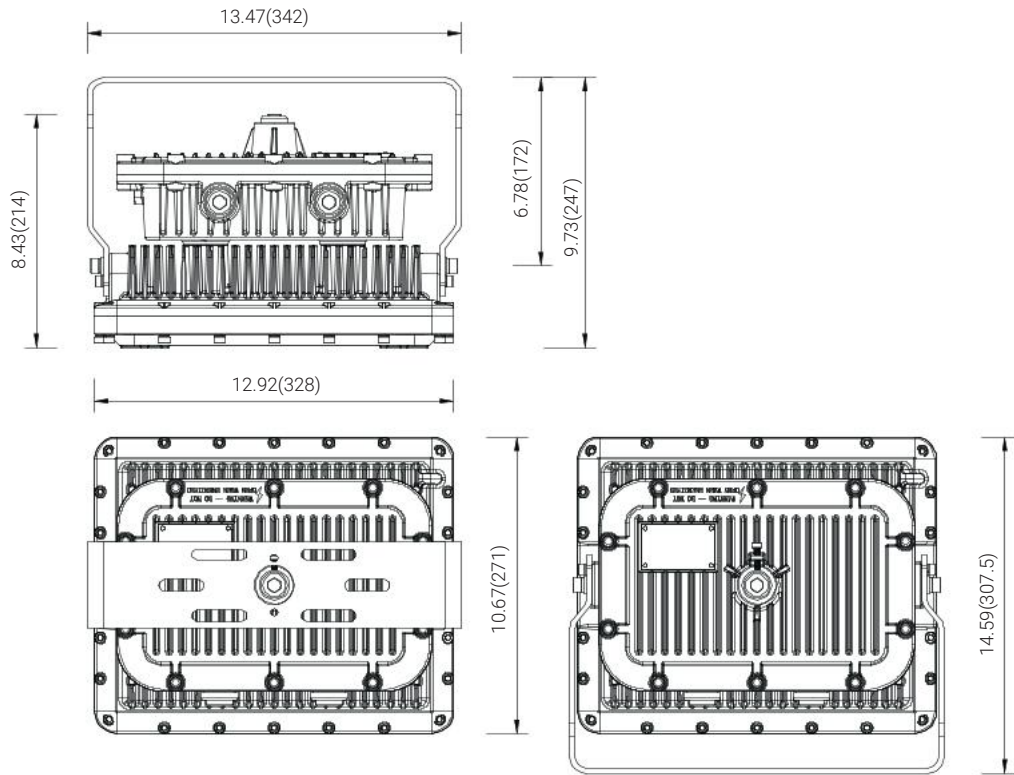

Yoke

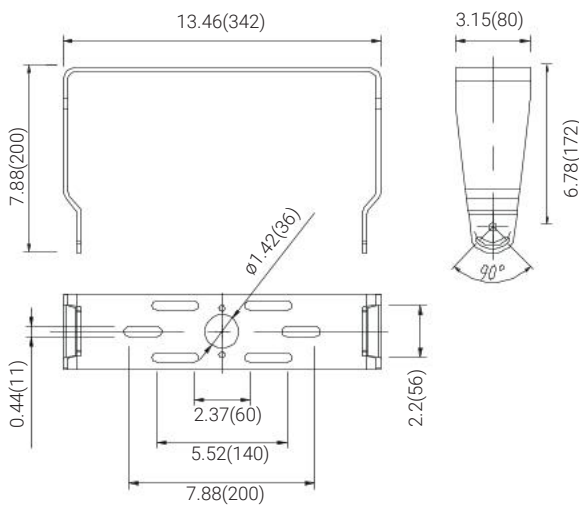

BLK-YOKE

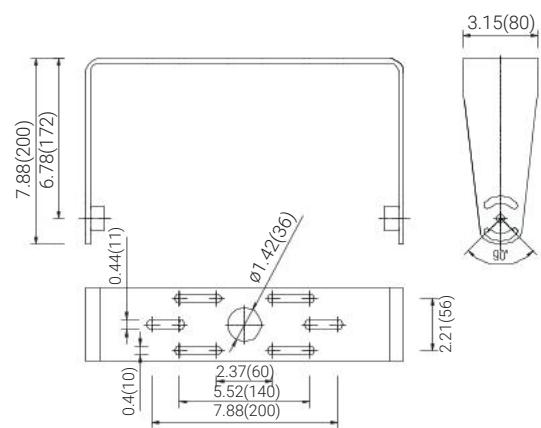

BLK-360Y

HAZARDOUS LOCATION LIGHTING BASICS

Atmosphere Groups

Temperature Classification

Substance	Hazard Class	Division Groups	Zone Groups	Max. Surface Temperatures	NEC® 500 CEC®	NEC® 505/IEC-Group II
Acetylene	Class I Flammable Gases	Group A	IIC	450°C(842°F)	T1	T1
Hydrogen		Group B	IIC	300°C(572°F)	T2	
Ethylene		Group C	IIB	280°C(536°F)	T2A	T2
Propane		Group D	IIA	260°C(500°F)	T2B	
Methane		Group D	IIA ²	230°C(446°F)	T2C	
Combustible Metal Dusts	Class II Combustible Dusts	Group E ¹	IIIC ³	215°C(419°F)	T2D	T3
Combustible Carbonaceous Dust		Group F	IIIB ³	200°C(392°F)	T3	
Combustible Dusts not in Group E or F (Flour, Grain, Wood, Plastics, Chemicals)		Group G	IIIB ³	180°C(256°F)	T3A	
Combustible Fibers and Flyings		Class III Fibers and Flyings	Not Applicable	IIIA ³	165°C(329°F)	
				160°C(320°F)	T3C	T4
				135°C(275°F)	T4	
				120°C(248°F)	T4A	T4
				100°C(212°F)	T5	T5
				85°C(185°F)	T6	T6

Note 1: Group E is applicable to Class II, Division 1 only.
 Note 2: Methane is a Group IIA Gas for non-mining applications.
 Note 3: Group IIIA, IIIB and IIIC have not been adopted by the Canadian Electrical Code.

Classification of Divisions and Zones

Hazard Level	Division Scheme	Zone Scheme	Definitions
Continuous Hazard	Division 1	Zone 0 / Zone 20	A place in which an explosive atmosphere is continually present
Intermittent Hazard		Zone 1 / Zone 21	A place in which an explosive atmosphere is likely to occur in normal operation
Hazard Under Abnormal Conditions	Division 2	Zone 2 / Zone 22	A place in which an explosive atmosphere is not likely to occur in normal operation, but may occur for short periods

IP Codes

1st No.	Solid Objects
0	No protection
1	Objects greater than 50mm
2	Objects greater than 12.5mm
3	Objects greater than 2.5mm
4	Objects greater than 1mm
5	Dust protected
6	Dust proof
2nd No.	Liquids
0	No protection
1	Vertically dripping
2	Dripping up to 15°
3	Limited spraying
4	Splashing from all directions
5	Hosing jets from all directions
6	Strong hosing jets from all directions
7	Temporary immersion
8	Continuous immersion
9	Steam-jet cleaning

IK Ratings

IK Code	Level of Protection Achieved
IK00	Not protected
IK01	Protected against 0.14 joules impact
IK02	Protected against 0.2 joules impact
IK03	Protected against 0.35 joules impact
IK04	Protected against 0.5 joules impact
IK05	Protected against 0.7 joules impact
IK06	Protected against 1 joules impact
IK07	Protected against 2 joules impact
IK08	Protected against 5 joules impact
IK09	Protected against 10 joules impact
IK10	Protected against 20 joules impact



+1 (262) 456-5002
contact@redskylighting.com
www.redskylighting.com

RED SKY LIGHTING LLC
9370 Pittsburgh Ave.
Rancho Cucamonga, CA 91730, USA

Disclaimer

All product information is subject to change without notice.
Please contact Red Sky Lighting or your sales representative for the most up-to-date specifications.

Rev.06 04/26