

# BLOCK SERIES X1

HAZARDOUS LOCATION LED LUMINAIRE



**Reliable. Durable. Efficient.**  
**2,400 to 19,000 lumen models**

**RED SKY**  
SERIOUSLY SAFE LIGHTS™

# PIONEERING INDUSTRIAL ILLUMINATION FOR HARSH & HAZARDOUS CONDITIONS

---

A leading manufacturer of premium LED lights for demanding work conditions

Headquartered in California, products assembled in the USA

Servicing global clients across 4 continents in metal processing, oil & gas, marine, manufacturing

Renowned for quality, dependability, client care and uncompromising safety standards

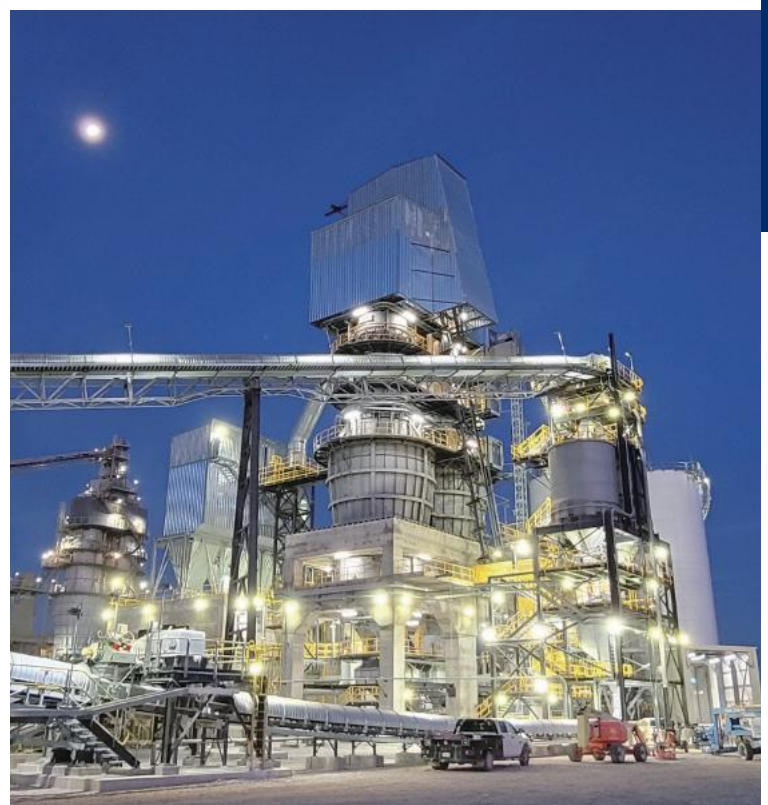

## WHY CHOOSE RED SKY

### ❧ SERIOUSLY SAFE LIGHTS

- Rigorously tested in our professional labs
- Surpassing industry certifications and safety protocols
- Crafted with highest grade components for maximum durability

### ❧ TOP-NOTCH SERVICES

- Team of experts for seamless support
- Energy audit services, lighting simulation services
- Hassle-free return policy and management

### ❧ FAST DELIVERY

- Majority of orders delivered within 14 days
- Same day shipping for products in stock
- Real-time order tracking for full transparency

### ❧ SUSTAINABLE SOLUTIONS

- High luminous efficacy LEDs for energy savings
- Conscious product design
- Recyclable materials for products and packaging



## BLOCK SERIES

### **FEATURES**



#### **Excellent Heat Dissipation**

Self-contained LED and Driver compartment with external air-flow fins provide exceptional heat dissipation to ensure long lifespan



#### **Easy and Through Wiring**

Built-in wiring compartment with NPT 3/4" entries and A quick-access WAGO 5-pole lever connector that allows for easy connection. (1mm<sup>2</sup>-4mm<sup>2</sup>)



### **RATINGS**

Zone 1&2  
Zone 21&22  
IP66  
IK08  
Salt Spray 720 hrs (ISO 9227)

### **CERTIFICATIONS**

**ATEX**  
II 2G Ex d IIB T5 Gb  
II 2D Ex tb IIIC (T 95°C Max) Db, IP 66  
**CE LVD/EMC**

# TECHNICAL PARAMETERS

Specification	BLK-X1-20	BLK-X1-40	BLK-X1-60	BLK-X1-80	BLK-X1-100	BLK-X1-120	BLK-X1-150
<b>Electrical Parameters</b>							
Power	20W	40W	60W	80W	100W	120W	150W
Rated Input Current (220V AC)	0.101A	0.202A	0.303A	0.404A	0.505A	0.606A	0.758A
Voltage/Frequency	100-240V AC, 50/60Hz						
Power Factor	≥0.90						
THD	<20%						
L70	440,000 hrs@50°C			450,000 hrs@50°C			
Surge Protection	L/N-FG 2KV, L-N 1KV			L/N-FG 4KV, L-N 2KV			
Supply Wire	1mm <sup>2</sup> -4mm <sup>2</sup> , Rated 90°C						
Warranty	5 Years						
<b>Optical Parameters</b>							
Lumen Output*	2,399Lm	5,046Lm	7,010Lm	11,629Lm	14,082Lm	17,642Lm	20,924Lm
Lumen Efficacy*	120Lm/W			130Lm/W			
Available Beam Angle	25° / 60° / 120°						
Correlated Color Temperature (CCT)	4000K/5700K						
Color Rendering Index (CRI)	Ra>70						
<b>Mechanical Parameters</b>							
Housing Material	Marine Grade Aluminium						
Hardware	Stainless steel 316						
Lens Material	Tempered Glass						
Mounting Options	Yoke, Stanchion						
Product Weight	10.1lbs/4.6kg			33.3lbs/15.1kg			
Package Weight	12.2lbs/5.6kg			35.4lbs/16.1kg			
Cable Entry	(1) 3/4" NPT			(2) 3/4" NPT			
Product Dimensions(L×W×H)	9.6×8×5.6in (243×203×141mm)			13.2×11×6.6in (336×279×168mm)			
Package Dimensions(L×W×H)	15×14.2×10.2in (380×360×260mm)			16.1×14.6×9.1in (410×370×230mm)			
<b>Environmental Parameters</b>							
Ambient Operating Temperature	-30°C ~ +50°C						
T-Code Ratin	Gas – T5, Dust – 95°C						
EPA wind rating (FT2/m2)	0.968/0.090 (Yoke), 0.988/0.092 (Stanchion)			1.715/0.160 (Yoke), 1.735/0.161 (Stanchion)			

\* Value calculated based on 5700K and clear glass ,varies to different spec.

# ORDERING INFORMATION

EXAMPLE: BLK-80-100-240-57K-120-X1-CG-GRY-YKE

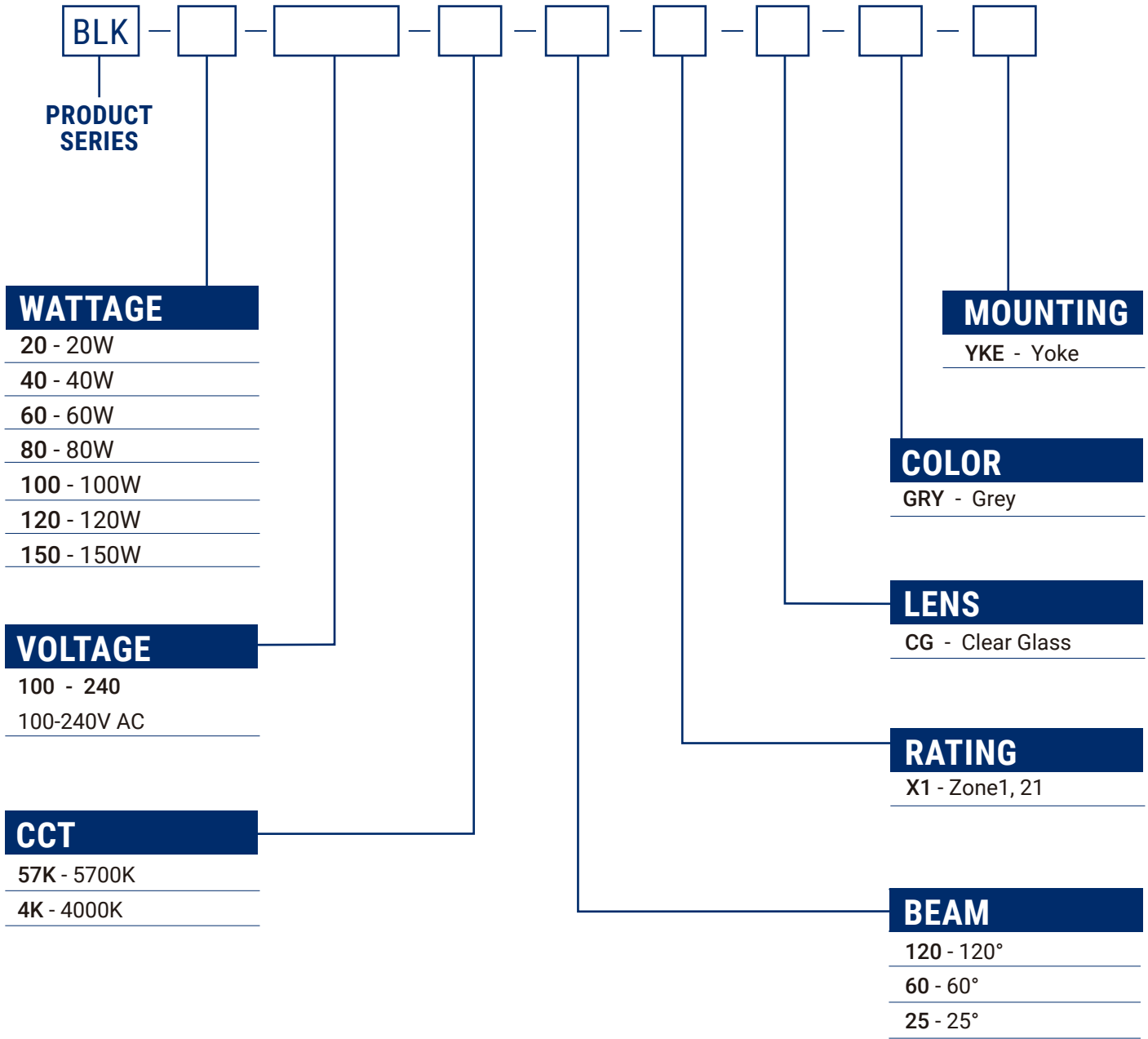

# MOUNTING ACCESSORIES

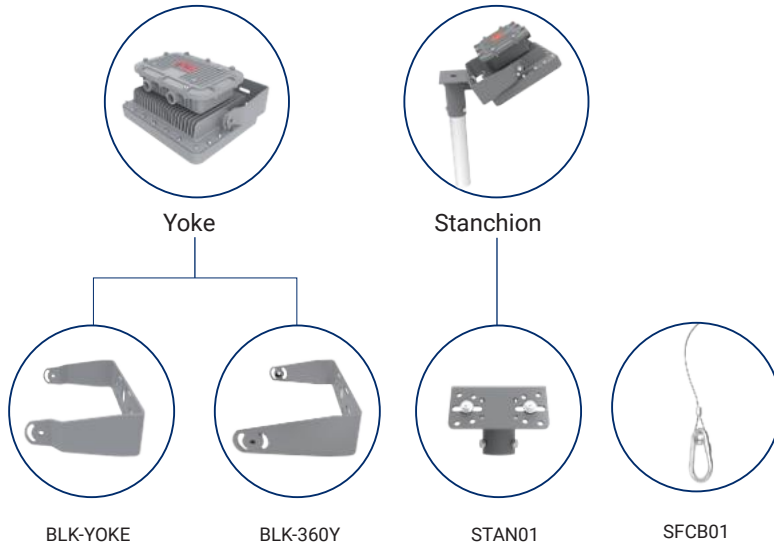

Mounting	PN	Description	MPN Code
Yoke	BLK-YOKE	Yoke Mount, SUS304, Powder-Coated Grey RAL 7037	210010013
	BLK-360Y	360-Degree Rotation Yoke Mount, SUS304, Powder-Coated Grey RAL 7037	210010082
Stanchion	STAN01*	Slip-Fit Stanchion Mount Kit for $\Phi$ 2 inch (2-3/8 inch OD, 60mm OD) Poles, Non-Threaded, SUS304, Powder-Coated Grey RAL 7037	210010031
	SFCB01	Safety Cable Kit, SUS304	210010086

\* Requires A Yoke Mount

## **REPLACEMENT PARTS (ORDERED SEPARATELY)**

Part Number	Description	MPN Code
BLK-X1-20-Driver	Replacement Driver Kit for BLK-X1-20 Fixtures	303010078
BLK-X1-40-Driver	Replacement Driver Kit for BLK-X1-40 Fixtures	303010079
BLK-X1-60-Driver	Replacement Driver Kit for BLK-X1-60 Fixtures	303010080
BLK-X1-80-Driver	Replacement Driver Kit for BLK-X1-80 Fixtures	303010081
BLK-X1-100-Driver	Replacement Driver Kit for BLK-X1-100 Fixtures	303010082
BLK-X1-120-Driver	Replacement Driver Kit for BLK-X1-120 Fixtures	303010083
BLK-X1-150-Driver	Replacement Driver Kit for BLK-X1-150 Fixtures	303010084
CG009-A-01	Replacement Clear Glass Lens for BLK X1 20W-60W	303030024
CG009-B-01	Replacement Clear Glass Lens for BLK X1 80W-150W	303030025

## **LUMEN TABLE**

Part Number	Wattage (W)	CCT	Beam	Lens	Lumen Output (Lm)	Efficiency (Lm/W)
<b>Voltage 100-240VAC</b>						
BLK-20-100-240-57K-120-X1-CG-GRY-YKE	20	5700K	120°	Clear Glass	2,399	116
BLK-40-100-240-57K-120-X1-CG-GRY-YKE	40	5700K	120°	Clear Glass	5,046	129
BLK-60-100-240-57K-120-X1-CG-GRY-YKE	60	5700K	120°	Clear Glass	7,010	119
BLK-80-100-240-57K-120-X1-CG-GRY-YKE	80	5700K	120°	Clear Glass	11,629	143
BLK-100-100-240-57K-120-X1-CG-GRY-YKE	100	5700K	120°	Clear Glass	14,082	139
BLK-120-100-240-57K-120-X1-CG-GRY-YKE	120	5700K	120°	Clear Glass	17,642	147
BLK-150-100-240-57K-120-X1-CG-GRY-YKE	150	5700K	120°	Clear Glass	20,924	142

This table lists only selected lumen packages. For additional model parameters, please contact our sales team.  
 Note: LXX# = nominal lumens. Verify lumen package before ordering.

# LUMEN MAINTENANCE

Hours Ambient	0	15,000	30,000	45,000	60,000	75,000	90,000	100,000	150,000
25°C	100%	99%	98%	97%	95%	94%	93%	93%	89%
35°C	100%	99%	98%	97%	95%	94%	93%	93%	89%
45°C	100%	99%	98%	97%	95%	94%	93%	93%	89%
50°C	100%	99%	98%	97%	95%	94%	93%	93%	89%

# LUMINAIRE LIFESPAN

Ambient Temperature	Luminaire Lifespan (Hours)	Rated Service Life - Years (24/7 Operation)	Rated Service Life - Years (12/7 Operation)
25°C (+77°F)	100,000	11	23
35°C (+95°F)	81,000	9	18
45°C (+113°F)	36,000	4	8
50°C (+122°F)	25,000	3	6

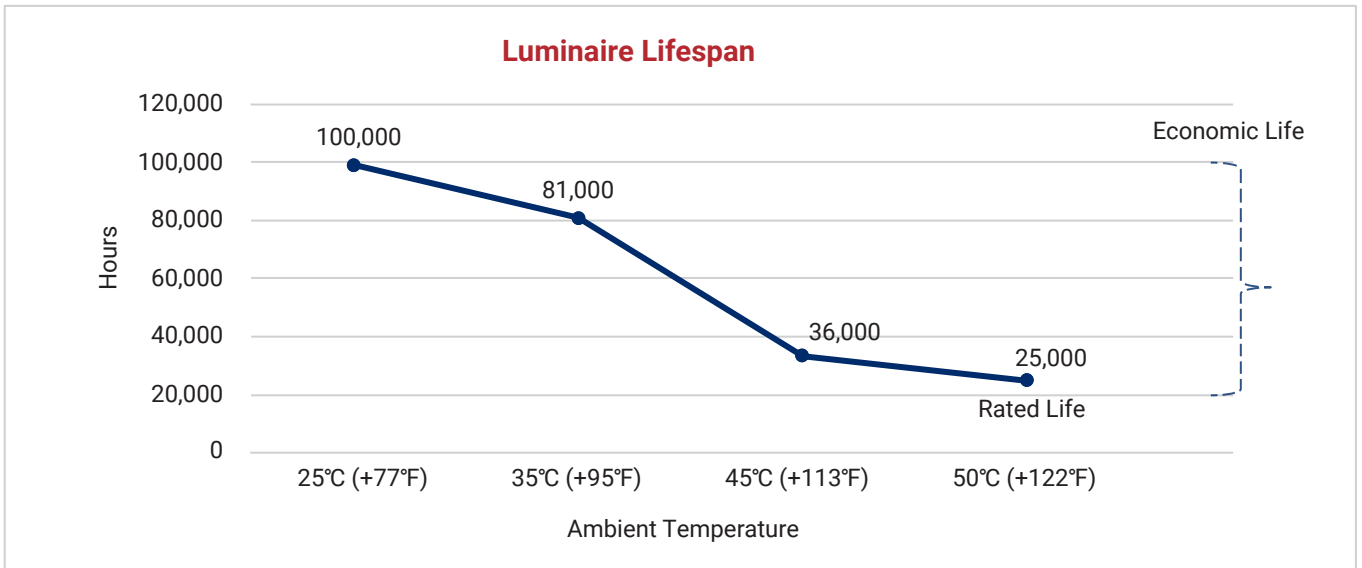

Information shown for reference only and may vary by configuration.

# A DIRECT RETROFIT FROM HID TO LED

The BLK X1 series LED is easy to retrofit in the same configuration as your existing HID luminaires. For example, a 150-watt Block (BLK-150-X1) delivers virtually the same illumination as its equivalent 400 watt MH luminaire while providing 75% reduction in energy costs and up to 140,000 hours of continuous operation.







MODELS	Lumen Output (Lm)	MH Equivalent (W)	HPS Equivalent (W)
BLK-20-X1	2,399	70	100
BLK-40-X1	5,046	100	150
BLK-60-X1	7,010	150	150
BLK-80-X1	11,629	200	250
BLK-100-X1	14,082	250	310
BLK-120-X1	17,642	350	400
BLK-150-X1	20,924	400	400

# THE RIGHT BEAM PATTERN FOR YOUR APPLICATION

RSL optic package is engineered to deliver maximum footcandles efficiently where you need them, without wasted light or overspill.

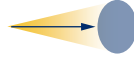
RSL offers complimentary lighting design services for our products using industry-leading AGI32 software, tailored for projects of all sizes in harsh and hazardous locations. We assist you in determining the number of fixtures needed, the types of lights to use, their optimal placement, and how to maximize energy savings—all within budget.

Simply fill out the form (<https://dev.redskylighting.com/lighting-design>) with a few key details, request a layout, and we'll bring your ideas to life within 2-5 business days.

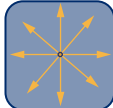
Beam	NEMA/IESNA Type	Beam Description	Beam Projection Distance
30°	NEMA 3	Medium Narrow	
60°	NEMA 4	Medium	
90°	NEMA 5	Medium Wide	
120°	NEMA 6	Wide	
T1	Type I	Asymmetric distributions, well suited for narrow areas, such as Conveyor belts, Aisleways, Catwalks, Loading docks and Tunnels.	
T2	Type II	Asymmetric distributions, well suited for narrow areas, such as roadways, paths and driveways.	
T3	Type III	Asymmetric distributions, well suited for site / area perimeters, wide roadways, and open areas.	
T5	NEMA 7 Type V (Square)	Very Wide: symmetrical pattern with excellent uniformity for large, open areas.	

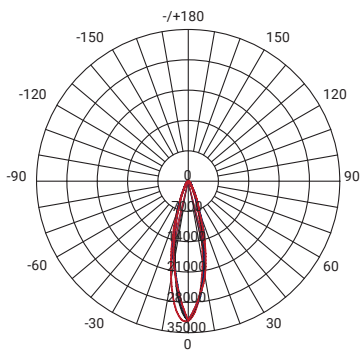

25°

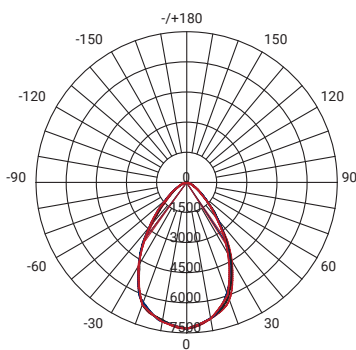

60°

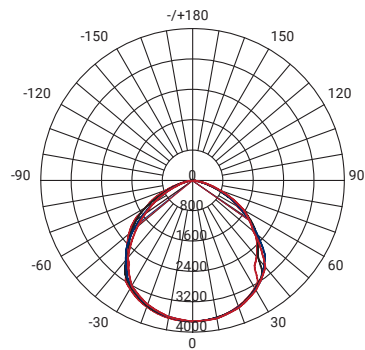

120°

## DIMENSIONS

unit: in(mm)

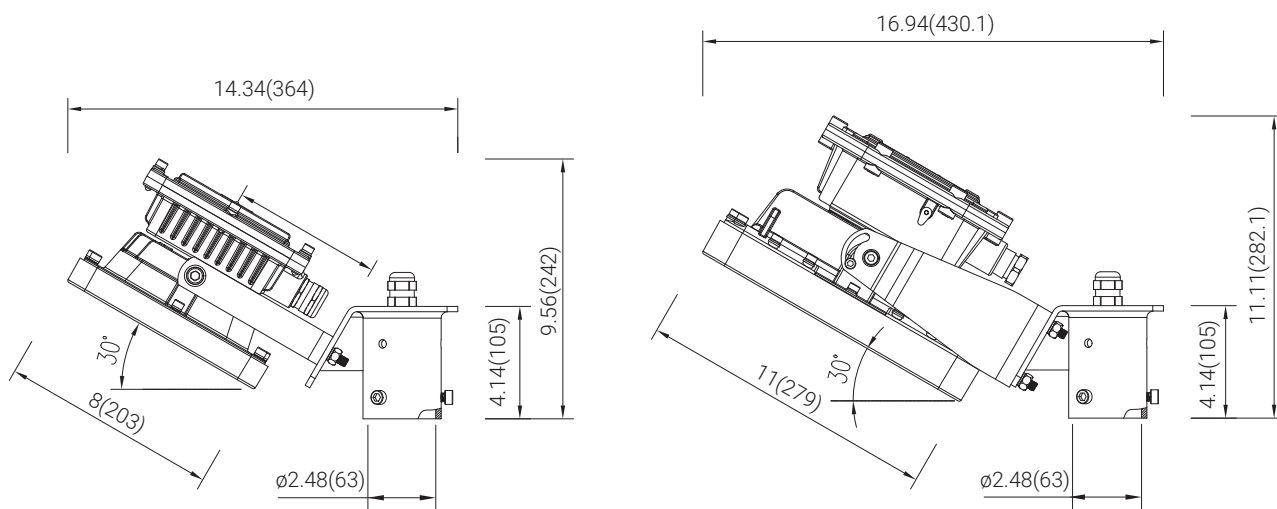

Stanchion

# DIMENSIONS

unit: in(mm)

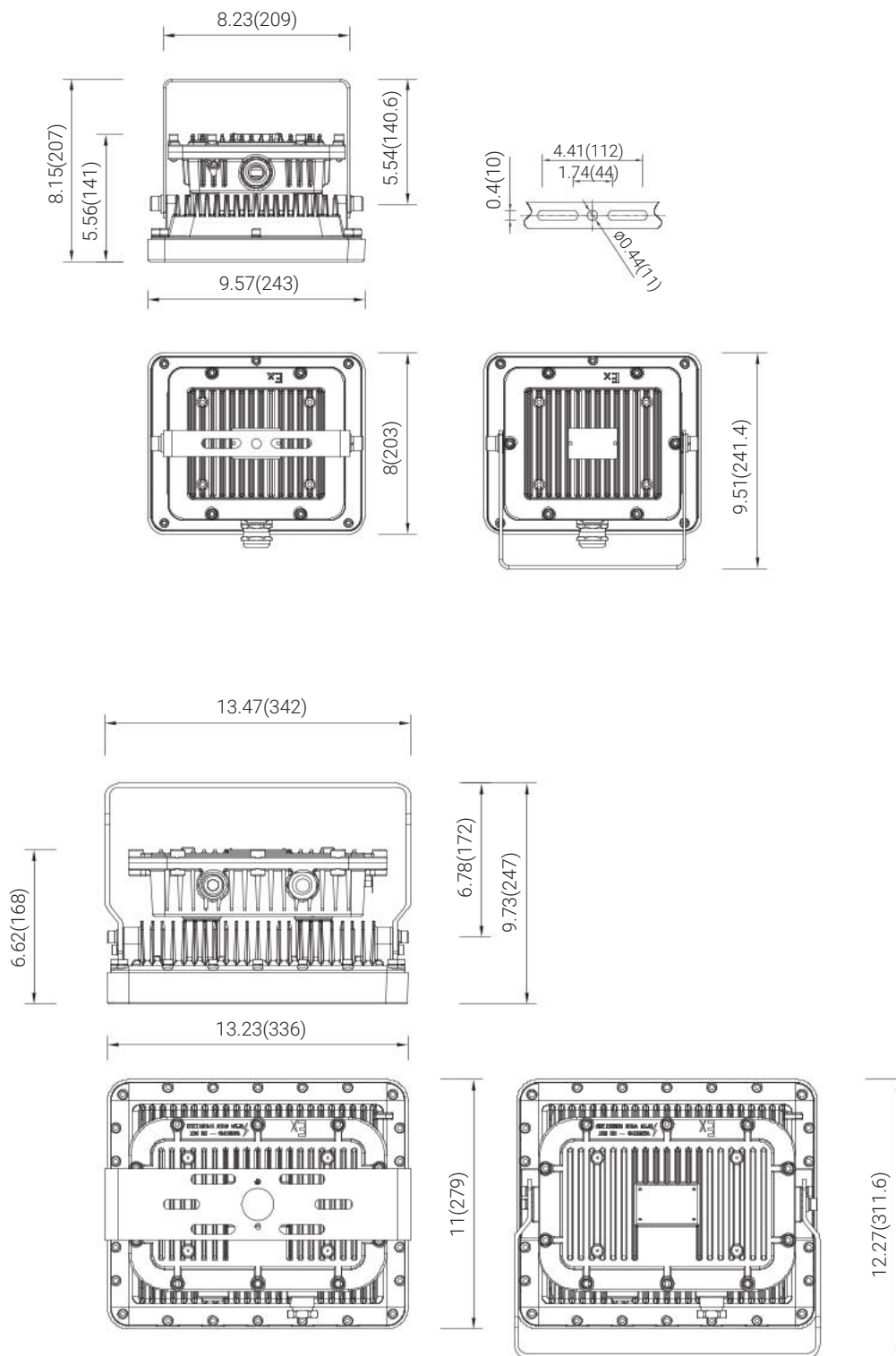

Yoke

unit: in(mm)

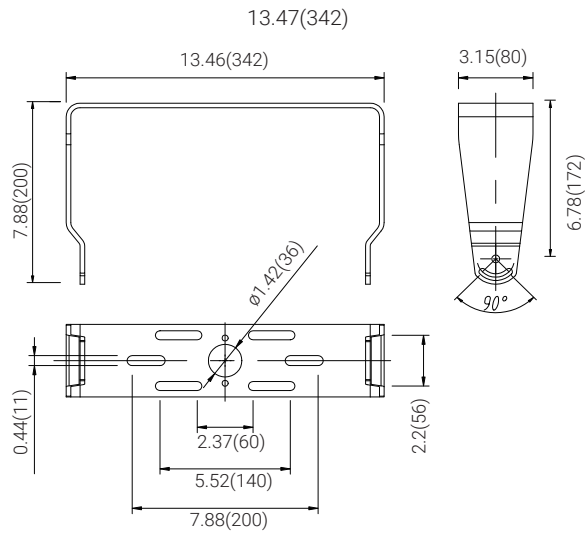

**BLK-YOKE**

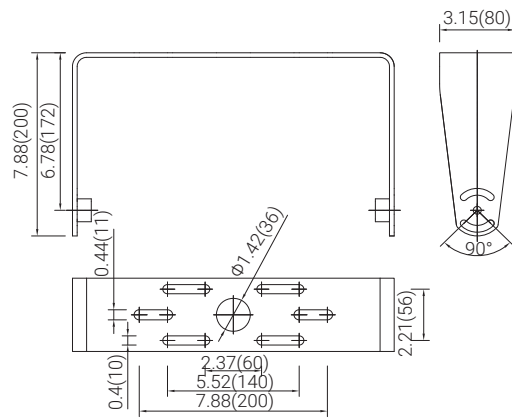

**YOKE-360Y**

# HAZARDOUS LOCATION LIGHTING BASICS

## Atmosphere Groups

## Temperature Classification

Substance	Hazard Class	Division Groups	Zone Groups	Max. Surface Temperatures	NEC® 500 CEC®	NEC® 505/IEC-Group II
Acetylene	Class I Flammable Gases	Group A	IIC	450°C(842°F)	T1	T1
Hydrogen		Group B	IIC	300°C(572°F)	T2	
Ethylene		Group C	IIB	280°C(536°F)	T2A	T2
Propane		Group D	IIA	260°C(500°F)	T2B	
Methane		Group D	IIA <sup>2</sup>	230°C(446°F)	T2C	
Combustible Metal Dusts	Class II Combustible Dusts	Group E <sup>1</sup>	IIIC <sup>3</sup>	215°C(419°F)	T2D	T3
Combustible Carbonaceous Dust		Group F	IIIB <sup>3</sup>	200°C(392°F)	T3	
Combustible Dusts not in Group E or F (Flour, Grain, Wood, Plastics, Chemicals)		Group G	IIIB <sup>3</sup>	180°C(256°F)	T3A	
Combustible Fibers and Flyings				Class III Fibers and Flyings	Not Applicable	
				160°C(320°F)	T3C	T4
				135°C(275°F)	T4	
				120°C(248°F)	T4A	T4
				100°C(212°F)	T5	T5
				85°C(185°F)	T6	T6

Note 1: Group E is applicable to Class II, Division 1 only.  
 Note 2: Methane is a Group IIA Gas for non-mining applications.  
 Note 3: Group IIIA, IIIB and IIIC have not been adopted by the Canadian Electrical Code.

## Classification of Divisions and Zones

Hazard Level	Division Scheme	Zone Scheme	Definitions
Continuous Hazard	Division 1	Zone 0 / Zone 20	A place in which an explosive atmosphere is continually present
Intermittent Hazard		Zone 1 / Zone 21	A place in which an explosive atmosphere is likely to occur in normal operation
Hazard Under Abnormal Conditions	Division 2	Zone 2 / Zone 22	A place in which an explosive atmosphere is not likely to occur in normal operation, but may occur for short periods

## IP Codes

1st No.	Solid Objects
0	No protection
1	Objects greater than 50mm
2	Objects greater than 12.5mm
3	Objects greater than 2.5mm
4	Objects greater than 1mm
5	Dust protected
6	Dust proof
2nd No.	Liquids
0	No protection
1	Vertically dripping
2	Dripping up to 15°
3	Limited spraying
4	Splashing from all directions
5	Hosing jets from all directions
6	Strong hosing jets from all directions
7	Temporary immersion
8	Continuous immersion
9	Steam-jet cleaning

## IK Ratings

IK Code	Level of Protection Achieved
IK00	Not protected
IK01	Protected against 0.14 joules impact
IK02	Protected against 0.2 joules impact
IK03	Protected against 0.35 joules impact
IK04	Protected against 0.5 joules impact
IK05	Protected against 0.7 joules impact
IK06	Protected against 1 joules impact
IK07	Protected against 2 joules impact
IK08	Protected against 5 joules impact
IK09	Protected against 10 joules impact
IK10	Protected against 20 joules impact



**+1 (262) 456-5002**  
contact@redskylighting.com  
www.redskylighting.com

**RED SKY LIGHTING LLC**  
9370 Pittsburgh Ave.  
Rancho Cucamonga, CA 91730, USA

#### **Disclaimer**

All product information is subject to change without notice.  
Please contact Red Sky Lighting or your sales representative for the most up-to-date specifications.

Rev.04 04/26