

Hazloc LED Luminaire

General Safety Information

- To reduce the risk of death, personal injury or property damage from fire, electric shock, falling parts, cuts/abrasions, and other hazards, read all warnings and instructions included with and on the fixture box and all fixture labels.
- Before installing, servicing, or performing routine maintenance on this equipment, please follow these general precautions.
- Commercial installation, servicing and maintenance of luminaires should be performed by a qualified licensed electrician.
- DO NOT INSTALL A DAMAGED PRODUCT!
- Make sure that the supply voltage is the same as the luminaire voltage.
- It is prohibited to increase the factory power of luminaires without authorization.
- Do not install in areas where the marked operating temperatures exceed the ignition temperatures of the hazardous atmosphere.
- Do not operate in ambient temperatures above those indicated on the luminaire nameplate.
- All gasket seals must be clean and undamaged.
- During installation, make sure that there are no scratches, gaps, or defects on the surface of the external coating. If damage is found and the substrate material of the housing is visible, restore the condition using the same coating material and process as the anti-corrosion coating of the product.



WARNING:

RISK OF ELECTRICAL SHOCK

- Turn off electrical power at the fuse or circuit breaker box before wiring the fixture to the power supply.
- Turn off the power when you perform any maintenance.
- Verify that supply voltage is correct by comparing it with the luminaire label information.
- Make sure all electrical and grounded connections are in accordance with the National Electrical Code and any applicable local code requirements and Hazloc requirements and suitable for wiring system.
- All wiring connections should be capped with UL approved wire connectors.
- Luminaire must be supplied by a wiring system with an equipment grounding conductor.

CAUTION:

RISK OF INJURY

- Tightly close when energized for safety.
- Do not open the luminaire after installation.
- Wear gloves and safety glasses at all times when removing luminaire from carton, installing, servicing or performing maintenance.
- Avoid direct eye exposure while the light source is on.
- Account for small parts and destroy packing material, as these may be hazardous to children.

Hazloc LED Luminaire

CAUTION:

RISK OF FIRE

- Keep combustible materials and other materials that can burn away from the luminaire and lamp/ lens.
- MIN 90°C SUPPLY CONDUCTORS

CAUTION:

- Do not cover the lamp body during product use to prevent the risk of fire and to avoid any negative impact on the product's lifespan.

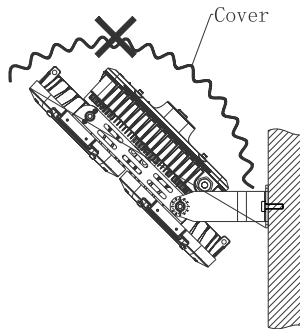

- Ceiling recessed installation is prohibited; if panel installation is carried out, ensure good ventilation behind the heat dissipation part of the luminaire. Otherwise, the lifespan of the product will be severely impacted.

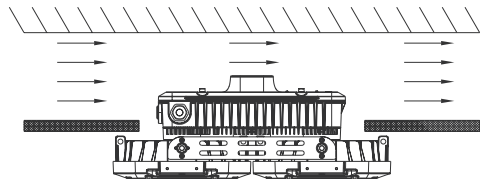
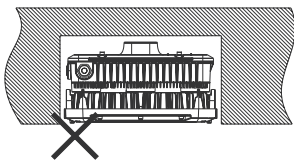

Hazloc LED Luminaire

This fixture is suitable for use in the following hazardous (classified) areas as defined by the National Electrical Code (NEC) and Canadian Electrical Code (CEC):

Hazardous Locations

Class I, Division 2, Groups A, B, C, D

Class II, Division 1, Groups E, F, G

Class II, Division 2, Groups F, G

Class III, Division 1

SIMULTANEOUS PRESENCE

Compliances

UL 1598

UL 844

UL 1598A

CSA C22.2 NO. 250.0:21, 5th Ed

CSA C22.2 No. 137, Edition: 2

Refer to the luminaire nameplate for specific classification information, maximum ambient temperature suitability and corresponding operating temperature (T-Code).

Environmental Ratings

Suitable for wet location

IP 66 / IP 67

MODELS:

MDX - 1- 2 - 3 - 4 - 5 - 6 - 7 - 8

1=Lumen Level (15L=15000Lm, 20L=20000Lm, 30L=30000Lm, 40L=40000Lm, 50L=50000Lm, 60L=60000Lm, 70L=70000Lm)

2=Voltage (100-277=100-277V AC, 347-480=347-480V AC,* 100-240/277V AC for 60L and 70L models)

3=CCT (5K=5000K, 4K=4000K, 27K=2700K)

4=Beam (30=30°, 60=60°, 90=90°, 120=120°no optics, T2=Typell, T3=Typelll, T5=TypeV)

5=Rating (H2=C1D2 / C2D1 / C3, HS=UL1598/A)

6= Lens (CG=Clear Glass)

7= Color (GRY=Grey)

8= Mounting (PND=Pendant, SYK=Straight Yoke, AYK=Angled Yoke)

Hazloc LED Luminaire

Operating Characteristic:

Rated voltage	Power	Model	Ambient Temp.	Tcode	
				C1D2	C2D1
100-277V AC	90W	MDX-15L	-45°C~+65°C	T3C	T4
	120W	MDX-20L			
	190W	MDX-30L			
	260W	MDX-40L	-45°C~+55°C		
	310W	MDX-50L			
100-240/277V AC	380W	MDX-60L			
	440W	MDX-70L			
347-480V AC	90W	MDX-15L	-45°C~+65°C		
	120W	MDX-20L			
	190W	MDX-30L			
	260W	MDX-40L	-45°C~+55°C		
	310W	MDX-50L			
	380W	MDX-60L			
	440W	MDX-70L			

General Wiring Diagram

CAUTION:

Turn off electrical power at fuse or circuit breaker box before wiring luminaire to the power supply.
All units must be individually connected to the AC supply.

Black = Line
White = Neutral
Green = Ground
Dimming control wire: Yellow =Vaux 12V dc
Purple = Dim+ 1~10V input
Pink* = Dim- (NEG)

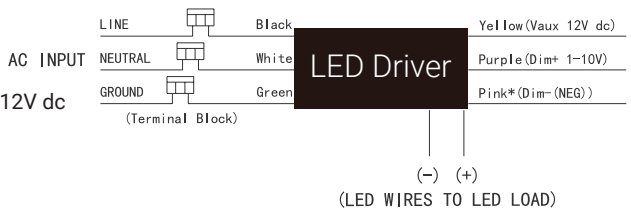

* for 60L and 70L models
Brown = Line
Blue = Neutral
Green/Yellow = Ground
Dimming control wire: Yellow =Vaux 12V dc
Purple = Dim+ 1~10V input
Pink* = Dim- (NEG)

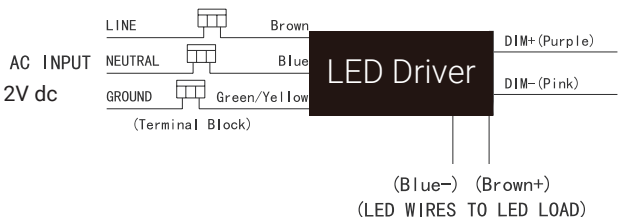

Hazloc LED Luminaire

Installation

Electrical Connection:

- Connect field supply wires to luminaire wire leads (Use Wago connectors, wire peeling 9mm, as shown in the diagram, the wire insulator is in contact with the internal conductor).
- Wire the luminaire per wiring diagram and per required electrical codes.
- Close the driver housing, making sure that all wires are safely inside the box.
- Check the tightness of the conduit and Tank Cover.
- Turn power on.

Product Dimensions

unit: in(mm)

1. Pendant:

Step 1. Loosen the four (M6) hexagon socket head cap screws of the hood with a torque value of 6 N-m.

Step 2. Thread the pendant hood onto the NPT 3/4 inch conduit. Tighten the (M5) set-screw with a torque value of 4 N-m.

Step 3. Wire per wiring diagram. Close driver housing. Tighten the four closing screws (M6) to (6 N-m).

Note: All installations must refer to NPT Assembly Instructions provided by Red Sky Lighting to prevent water leakage.

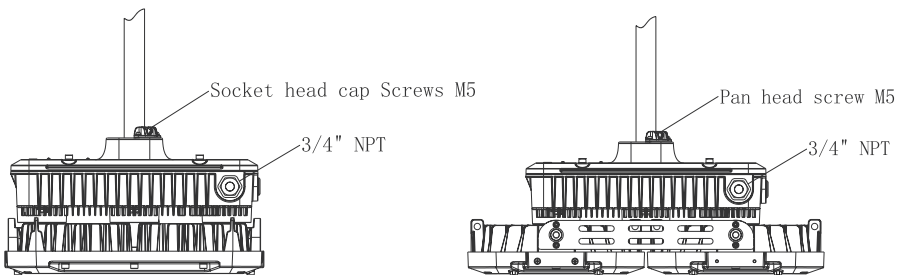

Hazloc LED Luminaire

2.Yoke (Ceiling / Wall / Floor):

Step 1. Secure the yoke and fixture with four (M10) or two (M12/M14) expansion bolts (not provided) directly to a structural member. Adjust the angle of the yoke and fix the position by tightening the two (M10) side screws (provided).

Step 2. Loosen the four (M6) hexagon socket head cap screws of the hood with a torque value of 6 N-m.

Step 3. Wire per wiring diagram. Close driver housing. Tighten the four closing screws (M6) to (6 N-m).

Note1: All installations must refer to NPT Assembly Instructions provided by Red Sky Lighting to prevent water leakage.

Note2: The Yoke is fixed to the bolt that the carrier is mounted on. Auxiliary flat washers and elastic washers should be installed to prevent the Yoke from loosening and causing damage to the anti-corrosion coating on the surface.

Ceiling Type:

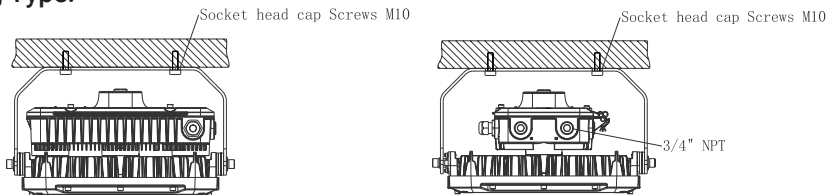

Wall Type:

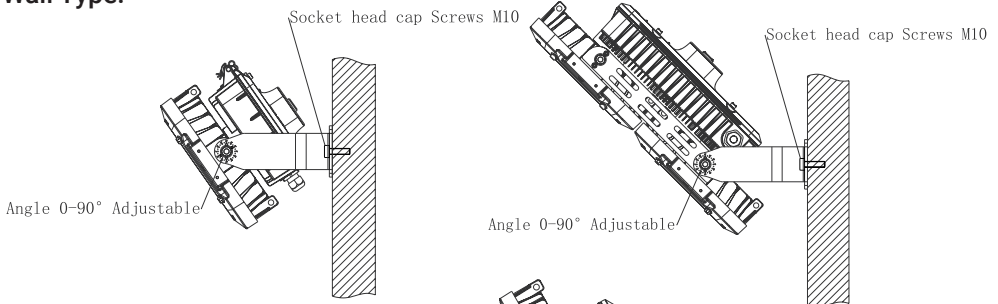

Floor Type:

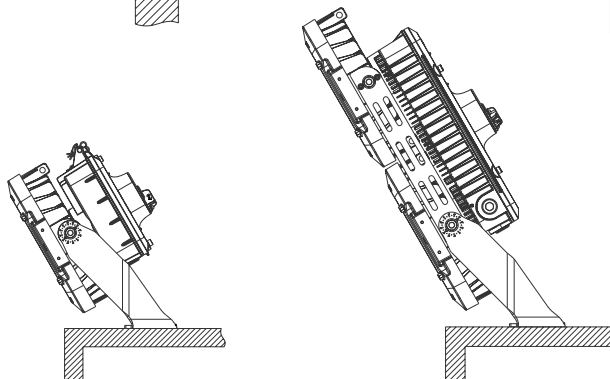

Hazloc LED Luminaire

3. Stanchion:

Step 1. Measure and verify pole outer diameter. Place Slip fitter on the 2-3/8" O.D. (60mm) Tenon. Tighten all 6 (M8x20mm) set screws. Pull cable through center hole.

Step 2. Place and hold the fixture with yoke onto Slip Fitter. Secure with the 2 (M10) hex bolts and washers on the top of the Slipfitter. This may require holding set screws in place with allen wrench.

Step 3. Loosen the Locking Bolt of the yoke and adjust the angle of the fixture as desired. Tighten the Locking Bolt.

Step 4. Wire to luminaire according to luminaire installation manual.

Note1: All installations must refer to NPT Assembly Instructions provided by Red Sky Lighting to prevent water leakage.

Note2: The Yoke is fixed to the bolt that the carrier is mounted on. Auxiliary flat washers and elastic washers should be installed to prevent the Yoke from loosening and causing damage to the anti-corrosion coating on the surface.

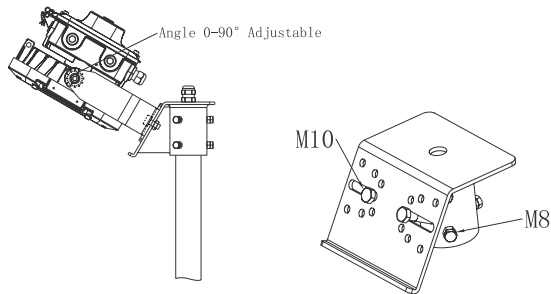

4. Chain:

Step 1. According to the diagram, hang the hooks of the accessory suspension cables (x4) onto the luminaire.

Step 2. Hang the other end of the suspension cables (x4) onto the hooks at the desired hanging position.

Note: All installations must refer to NPT Assembly Instructions provided by Red Sky Lighting to prevent water leakage.

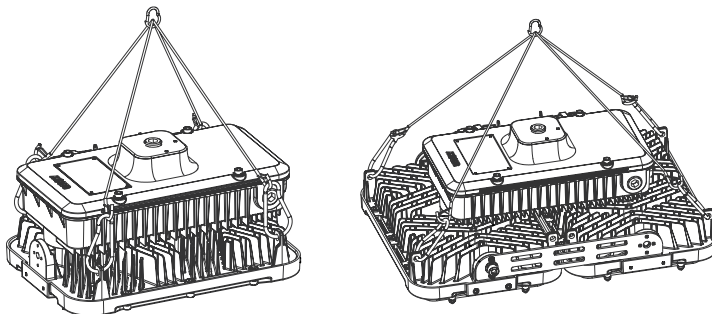

Hazloc LED Luminaire

Hook

Step 1. Assembly the suspension ring/hook, serrated washer, and adapter in order.

Step 2. Remove the original 3/4" plug from the top of the hood, then screw in the assembled suspension ring/hook component into the 3/4" threaded hole.

Step 3. Suspend the luminaire to the desired position.

Note: All installations must refer to NPT Assembly Instructions provided by Red Sky Lighting to prevent water leakage.

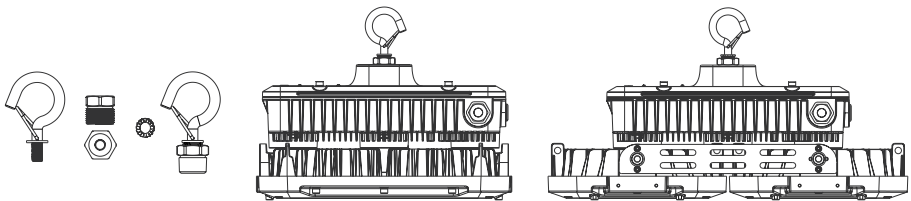

Wire Guard Installation (kit Sold Separately)

Step 1. Loosen the 4 (M4x10) screws of the lens cover with a torque value of 1.5 N-m.

Step 2. Place the lens wire guard symmetrically above the glass of the luminaire, then tighten the 4 (M4x10) screws with a torque value of 1.5 N-m.

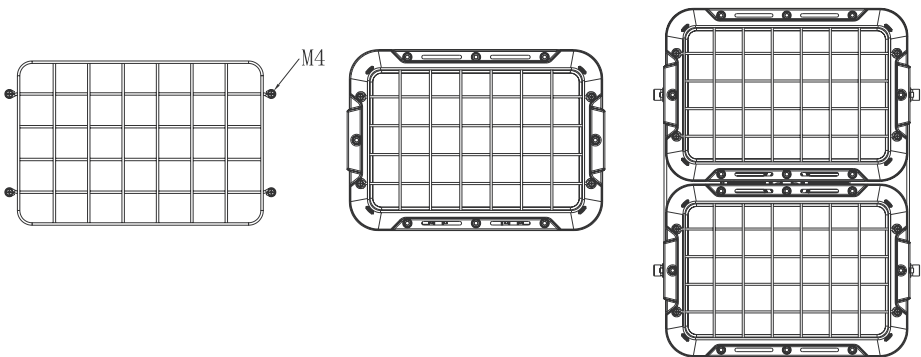

Hazloc LED Luminaire

Safety Cable Kit Installation

Step 1. Install Secondary Retention Cable to secure location per standards.

Step 2. Secure Carabiner through thru-holes (Dia-9mm) on top of the fixture.

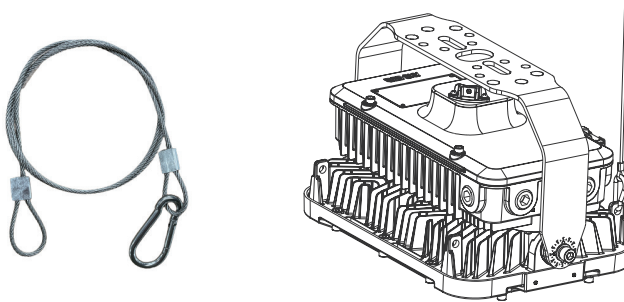

Visor Installation

Step 1. According to the diagram, install the visor at the illustrated position on the luminaire, aligning with the four holes on both sides.

Step 2. Install 4 combination screws (M4x8, 2 on each side), then tighten the 4 (M4x10) screws with a torque value of 1.5 N-m.

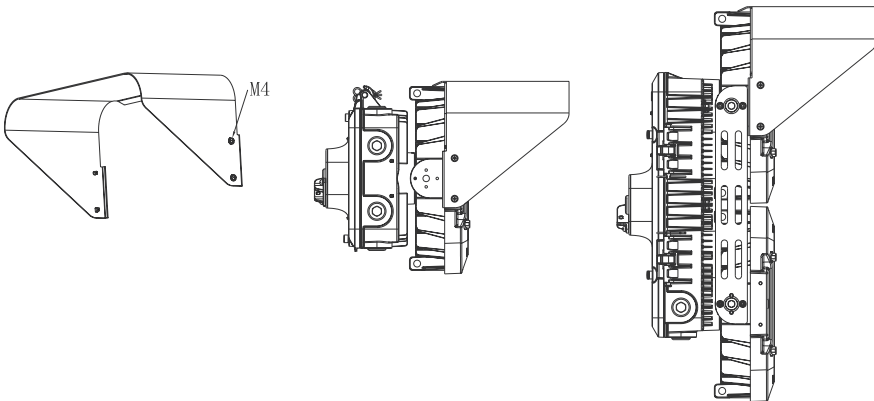

Hazloc LED Luminaire

INSTALLATION CHECKLIST

1. Verify if the steel pipe or cord grip are installed to at least five (5) full threads into the conduit entries of the fixture.



2. Verify field supply wires to luminaire (Wago connectors) are in accordance with the wiring diagrams and all electrical connections are tightened.



3. Verify all wires are safely and neatly inside driver housing, Gasket of the housing is placed into the slot nicely and evenly.

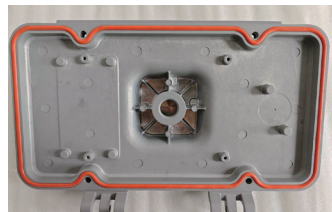

4. Verify captive closing screw is tightened to (6 N-m).



5. Follow RSL " NPT Assembly Instructions " to prevent water leakage.

Hazloc LED Luminaire

Maintenance

- To avoid personal injury, disconnect power to the light and allow the unit to cool down before performing maintenance.
- Perform regular visual, electrical, and mechanical inspections based on the environment and frequency of use. However, it is recommended to perform these inspections at least once a year based on the environment and frequency of use.
- The external glass should be cleaned periodically to ensure continued luminaire performance. Clean the glass with a clean, damp, non-abrasive, lint-free cloth. If this is not sufficient, use a mild soap or a "liquidcleaner". Do not use an abrasive, strong alkaline or acid cleaner as damage may occur.
- Inspect the cooling fins and housing on the luminaire to ensure that they are free of any contamination. Clean with a non-abrasive cloth if needed.
- Mechanically check to make sure all parts are properly assembled.
- Electrically check to make sure that all connections are clean and tight.

Warranty

We warrant that each of our LED lighting luminaire (the "Product(s)") that are purchased while this Warranty is in effect will be free from defects in materials and workmanship for the period of time specified in the table below (the "Warranty Period"). The Warranty Period runs from the date of original purchase from its authorized distributor/dealer.

We will repair, or at our option, replace the defective product (exterior finish, housing and heat sinks, lens, LED engine, power supply) during the standard warranty period. This warranty applies only to the repair or replacement of the product and only when the product is properly handled, installed and maintained according to our instructions.

This warranty excludes defects resulting from improper installation, acts of God, fire, vandalism or civil disturbances, power surges or improper power supply, and corrosive environment installations.

This warranty does not cover equipment, systems or components from other manufacturers that the Purchaser uses in conjunction with the Product. Any repair, alteration or modification of the Product, including replacement of Product components with components of other manufacturers will void the warranty in its entirety

Product	Which Model Nos. are Covered by this Warranty	Warranty Period
HazLoc LED Luminaire	MDX-XXX-xxx-xxx	Standard: 7 Years; Extended: 10 years

Hazloc LED Luminaire

NPT Assembly Instructions:

STEP 1: Inspect the port and fitting to ensure that both are free of contaminants and excessive burrs and nicks.

STEP 2: Apply a stripe of an anaerobic liquid pipe sealant around the male threads leaving the first two threads uncovered. If no liquid sealant is available, wrap Teflon tape (width of 12.7mm and thickness of 0.1mm) 2.5 - 3 turns in a clockwise direction, viewed from the pipe end, leaving the rest two threads uncovered.

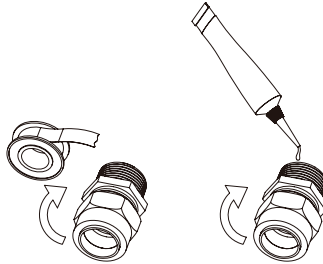

CAUTION: Teflon tape and some pipe sealants are destructive to hydraulic components. Always use extreme caution and follow manufacturer's recommendations for proper application of any sealant in order to prevent contamination.

STEP 3: Screw the fitting into the port.

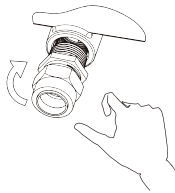

STEP 4: Wrench tighten the fitting to the correct Turns Past Finger Tight position. A properly assembled fittings total thread engagement should be ≥ 5 turns.

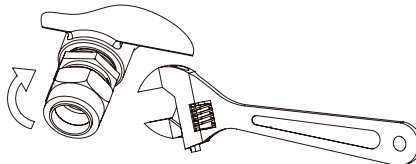

CAUTION: Never back off an installed pipe fitting to achieve proper alignment. Loosening installed pipe fittings will corrupt the seal and contribute to leakage and failure. (*Applicable standard: ASME B1.20.1-2013)