

Hazloc LED Luminaire

General Safety Information

- To reduce the risk of death, personal injury or property damage from fire, electric shock, falling parts, cuts/abrasions and other hazards, please read all warnings and instructions included with and on the fixture box and all fixture labels
- Before installing, servicing, or performing routine maintenance upon this equipment, please follow these general precautions
- Commercial installation, service and maintenance of luminaires should be performed by a qualified licensed electrician
- DO NOT INSTALL DAMAGED PRODUCT!
- Make sure that the supply voltage is the same as the luminaire voltage
- Do not install where the marked operating temperatures exceed the ignition temperatures of the hazardous atmosphere
- Do not operate in ambient temperatures above those indicated on the luminaire nameplate
- All gasket seals must be clean and undamaged.



SPECIAL CONDITIONS OF USE

1. To minimize the electrostatic discharge, wipe the enclosure surface with a damp cloth only.
2. The cable entry holes must be connected by means of suitable cable entry devices which are certified separately with ATEX certificate and the IP degree of cable entries shall be IP66 as a minimum. No tension or pulling is allowed on the entry cable, it can impair the explosion safety of the equipment.
3. The unused entry holes must be blocked by means of suitable blanking elements which are separately certified separately with ATEX certificate and the IP degree of blanking elements shall be IP66 as a minimum.
4. The installation must be installed according to the requirements of EN 60079-14: latest version (or its National equivalent standards).

Hazloc LED Luminaire

Nameplate (ATEX)

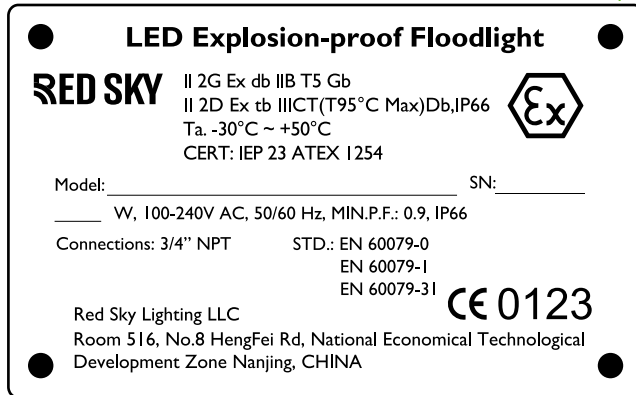

WARNING: .
WARNING - DO NOT OPEN WHEN AN EXPLOSIVE IS PRESENT.
WARNING - POTENTIAL ELECTROSTATIC CHARGING HAZARD- SEE INSTRUCTIONS.
WARNING - DO NOT OPEN WHEN ENERGIZED.

CAUTION:
 You can prevent static electricity by wiping with a wet cloth;
 Wear gloves and safety glasses at all times when removing luminaire from carton, installing, servicing or performing maintenance;
 Avoid direct eye exposure to the light source while it is on;
 Properly handle small parts and destroy packing material,as these may be hazardous to children.

Hazloc LED Luminaire

Warranty

We warrant that each of our LED lighting luminaire (the "Product(s)") that are purchased while this Warranty is in effect will be free from defects in materials and workmanship for the period of time specified in the table below (the "Warranty Period"). The Warranty Period runs from the date of original purchase from its authorized distributor/dealer.

We will repair, or at our option, replace the defective product (exterior finish, housing and heat sinks, lens, LED engine,power supply) during the standard warranty period. This warranty applies only to the repair or replacement of the product and only when the product is properly handled, installed and maintained according to our instructions.

This warranty excludes defects resulting from improper installation, acts of God, fire, vandal-ism or civil disturbances, power surges or improper power supply, and corrosive environment installations. This warranty does not cover equipment, systems or components from other manufacturers that the Purchaser uses in conjunction with the Product. Any repair, alteration or modification of the Product, including replacement of Product components with components of other manufacturers will void the warranty in its entirety.

LED Product	Model(s) Covered by Warranty	Warranty Period
Hazloc LED Luminaire	BLK XX-xxx-xxx	Five (5) Years

Limitation of Liability

THE FOREGOING WARRANTY IS EXCLUSIVE, AND IS THE SOLE REMEDY FOR ANY AND ALL CLAIMS, WHETHER IN CONTRACT, IN TORT OR OTHERWISE ARISING FROM THE FAILURE OF PRODUCT AND IS IN LIEU OF ALL OTHER WARRANTIES, EXPRESS OR IMPLIED, INCLUDING ALL WARRANTIES OF MERCHANTABILITY OR FITNESS FOR A PARTICULAR PURPOSE, WHICH WARRANTIES ARE HEREBY EXPRESSLY DISCLAIMED TO THE EXTENT PERMITTED BY LAW AND, IN ANY EVENT, SHALL BE LIMITED TO THE WARRANTY PERIOD SPECIFIED ABOVE. THE LIABILITY OF SHALL BE LIMITED TO THE TERMS OF THE EXPRESS WARRANTY SET FORTH HERE IN. IN NO EVENT WILL BE LIABLE FOR ANY SPECIAL, INCIDENTAL OR CONSEQUENTIAL DAMAGES INCLUDING, WITHOUT LIMITATION, DAMAGES RESULTING FROM LOSS OF USE, PROFITS, BUSINESS OR GOODWILL,LABOR COSTS, REMOVAL OR INSTALLATION COSTS, DECREASE IN THE LIGHT OUTPUT OF THE LAMP, AND/OR DETERIORATION IN THE LAMP'S PERFORMANCE, WHETHER OR NOT HAS BEEN ADVISED OF THE POSSIBILITY THEREOF. UNDER NO CIRCUMSTANCES SHALL 'S ENTIRE LIABILITY FOR A DEFECTIVE PRODUCT EXCEED THE PURCHASE PRICE OF THAT PRODUCT. WARRANTY SERVICES PROVIDED UNDER THESE TERMS AND CONDITIONS DO NOT ENSURE THE UNINTERRUPTEDOPERATION OF PRODUCTS; SHALL NOT BE LIABLE FOR DAMAGES CAUSED BY ANY DELAYS INVOLVING WARRANTY SERVICE.

This Limited Warranty gives you specific legal rights and you may also have other rights that may vary from state to state. Because some states or jurisdictions do not allow the exclusion or limitation of liability for consequential or incidental damages, this limitation may not apply to you

Hazloc LED Luminaire

Repair and maintenance

Repair and maintenance work shall be conducted by the end user only after the LED linear light isn't energized. Repair and maintenance shall be conformed to EN&IEC 60079-19.

In addition, the relevant national regulation which apply to the maintenance/servicing of electrical apparatus in explosive atmospheres shall be observed.

Any unforeseen repairs or overhaul may only be carried out with RSL spare parts. LED driver and LED lens chamber must not be repaired by the end user.

NOTE:

Should the luminaire enclosure be damaged, only a full luminaire replacement will be permitted. In case of doubt, the equipment should be returned to RSL for inspection/repair.

WARNING:

Modifications to the device or changes of its design are not permitted.

This equipment must be operated according to the intended purpose in a perfect and undamaged condition.

Inspection

Within the scope of maintenance or inspection routine the following should be included:

- Protective hoses covering the connection cables
- Cable entries must be free of corrosion.
- Perform visual mechanical and electrical inspections on a regular basis. We recommend routine checks to be made on a yearly basis.
- The PC cover should be cleaned periodically as needed to ensure continued photometric performance.
- Inspect the luminaire to ensure that it is free of any obstructions or contamination (i.e. excessive dust build up). Clean with a non-abrasive, damp cloth if needed.

Internal and external grounding

Internal earthing are provided in the terminal compartment and end shield. The internal earthing bolt: M4X6, torque is 3Nm, the section area of internal earthing wire is 0.84 mm².

The external bonding is provided on the external surface of end shield. The bolt is M6X10 hexagon socket cap screws. The external earthing wire is 4 mm². The torque of external bonding is 4Nm.

External bondings are secured against loosen.

Open the light

Use hexagonal wrench to untighten the screws of the driver cavity then the LED driver can be installed or replaced by the end user. How to replace the LED driver shall contact RSL authorized distributor. The driver must not be replaced by other brands.

Hazloc LED Luminaire

Ordering Information:

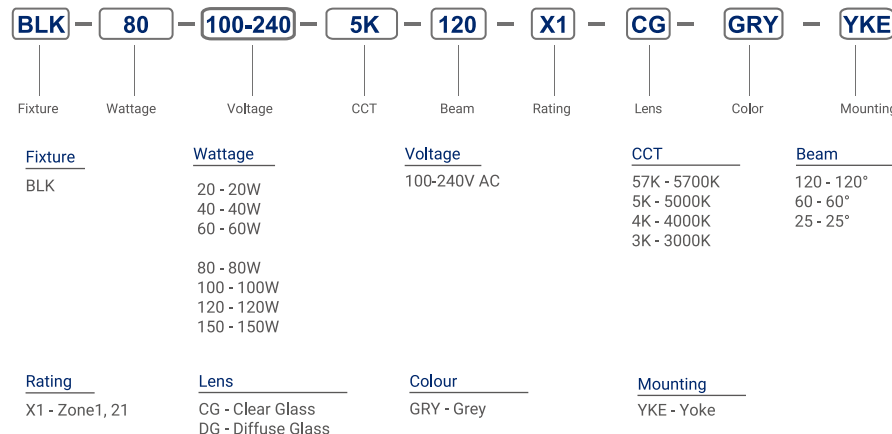

Packing List

- 1* LED Luminaire
- 1* Accessories box
- 1* Installation Manual

Operating characteristic

Rated voltage:	Power	Model	Ambient Temp.
100-240 Vac	20W	BLK-X1-20	-30°C~+50°C
	40W	BLK-X1-40	
	60W	BLK-X1-60	
	80W	BLK-X1-80	
	100W	BLK-X1-100	
	120W	BLK-X1-120	
	150W	BLK-X1-150	

Hazloc LED Luminaire

General Wiring Diagram

CAUTION:

Explosion-proof LED Luminaire Turn off electrical power at fuse or circuit breaker box before wiring fixture to the power supply

- 1.Connect supply wires to luminaire wire leads per the wiring diagram using methods that comply with all applicable codes.
- 2.Turn power on.
- 3.Check whether it concerns an AC(Alternating Current)based or DC(Direct Current)based system.

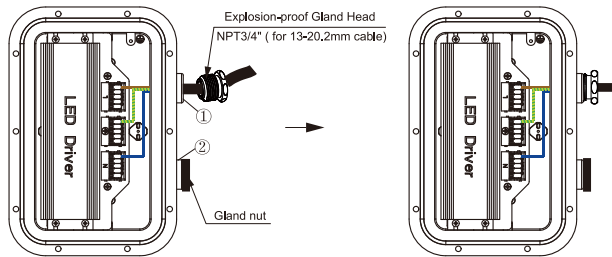

Troubleshooting:

Symptom	Solution
Luminaire does not turn on.	<ul style="list-style-type: none"> • Check that the color of the supply side wires matches the color of the wires they are connected to. • Check that all wire connectors are properly connected • Verify that your input voltage is within specs. • If you are using any additional controls IE wireless controls / motion sensors, please also verify that those are working properly and that the unit is setup to interface with the controllers.
Mounting insert slides from side to side.	<ul style="list-style-type: none"> • Check that the mounting insert is properly tightened using the adjustment screws provided.

- The product should not be placed in municipal waste.
- Check local regulations for disposal of electronic products.
- Features and specifications are subject to change without notice.

General product information

The model BLK X1 series LED Explosion-Proof Lights are suitable for use in Zone 1 and Zone 21 explosive atmospheres. The light consists of two chambers. One is the wiring compartment in protection type Ex eb, where the LED driver evaluated in protection of Ex mb. The other is the LED array chamber in protection type Ex eb with LED lens in protection type Ex db. The light transmitting cover is made of PC. that is surrounded by stainless steel press plate. The enclosure of light is made of aluminium.

BLK X1 series Explosion-Proof Lights are intended to be used in Zone 1, Zone 21 and Zone 22.

Depending on the characteristics of the radiation it might then be able to ignite a surrounding explosive atmosphere, the optical radiance from LED chamber and LED indicator are considered according to EN/IEC 60079-28. And the irradiance of optical radiation sources is lower than 5 mW/mm²

Hazloc LED Luminaire

D: Floor Type

1. According to the bracket hole distance, installed two M10 bolts on the ground or pipe stand.
2. Tighten the bracket from two sides to wrench tight.
3. Bolt the universal mounting bracket and tighten the M10 bolts to the field mounting point.
4. Wiring.(Connect supply wires to luminaire wire leads per the wiring diagram using methods that comply with all applicable codes.)

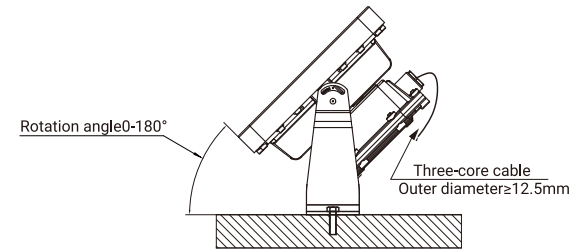

Servicing

To avoid personal injury, disconnect power to the light and allow the unit to cool down before performing maintenance.

Perform visual, electrical, and mechanical inspections on a regular basis. The environment and frequency of use should determine this. However, it is recommended that checks should be made at least once a year.

The external Lens should be cleaned periodically to ensure continued luminaire performance. Clean the Lens with a clean, damp, non-abrasive, lint-free cloth. If this is not sufficient, use a mild soap or a liquid cleaner. Do not use an abrasive, strong alkaline or acid cleaner as damage may occur.

Inspect the cooling fins of the luminaire to ensure that they are free of any contamination (i.e. excessive dust build-up). Clean with a non-abrasive cloth if needed.

Mechanically check to make sure all parts are properly assembled.

Electrically check to make sure that all connections are clean and tight

Hazloc LED Luminaire

Installation:

C. Pendant Type

1. Install a M20 eyebolt or hook on the roof;
2. Tighten the bracket from two sides to wrench tight.
3. Tighten the M10 eyebolt attached to the hanging ring to ensure the hanging ring is securely connected to the light fixture.
4. Wiring. (Connect supply wires to luminaire wire leads per the wiring diagram using methods that comply with all applicable codes.)

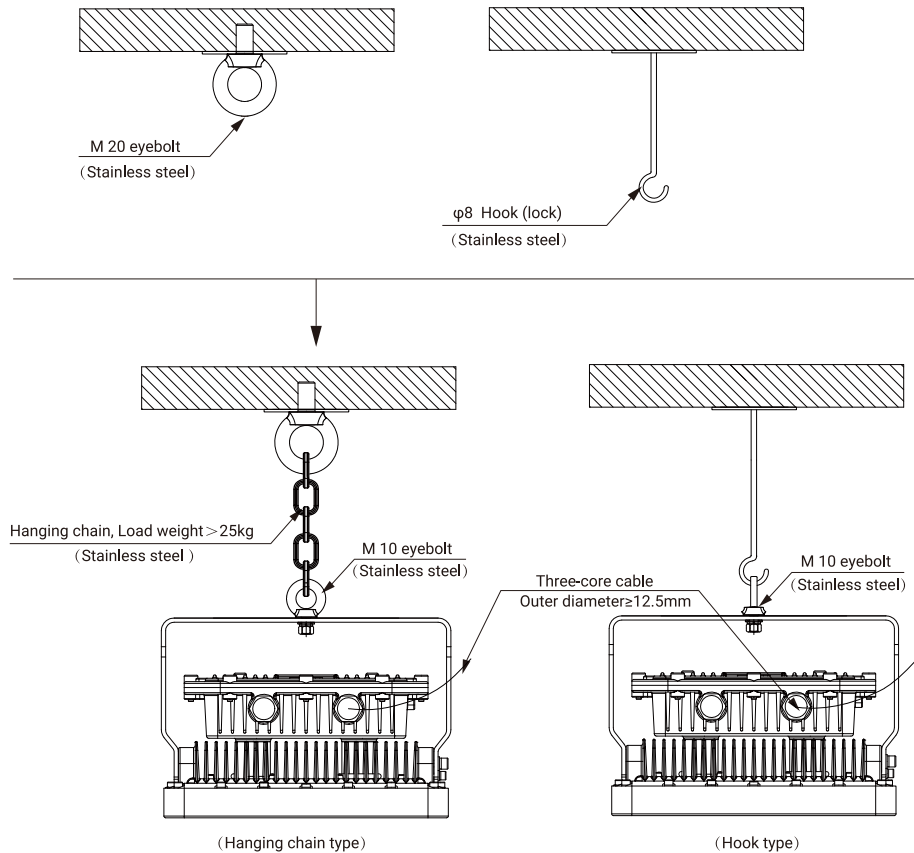

Hazloc LED Luminaire

Installation & Operation

Electrical Connection

1. Loosen the M6 hexagon bolts of terminal cover at torque value 3 N-m;
2. The thread of entry hole of Tank is 3/4" NPT. Connect the Tank to suitable conduit;
3. The user shall be equipped the cable entry device with an explosion-proof lead-in device and the plug is 3/4" NPT; Inset the wire from outside through the conduit and the entry hole of Tank, and then connect to terminal block;
4. Introduce the wires of branch circuit as following:
 - Brown-wire connects to Line
 - Blue-wire connects to Neutral
 - Green-wire connects to Ground
5. Re-attach the terminal cover and tighten it by the M6 hexagon bolts of terminal cover at torque value 3 N-m;
6. Check the tightness of conduit and terminal cover.

NOTE: Parts necessary to achieve a specific type of protection or used to prevent access to uninsulated live parts shall be capable of being released or removed only with the aid of a tool.
 NOTE: Further information on the installation of conduit or associated fittings into threaded or plain holes can be found in EN 60079-14.

7. When connecting the conductors, extra care should be taken in order to maintain the hazardous protection. The installation of the conductors shall reach up to the terminal block. The conductor itself shall not be damaged. The conductor cross sections shall be observed (see electrical connection data).

Product Size:

- (80W/100W/120W/150W)

A	B	C	D	E
218	159	4	336	279

- (20W/40W/60W)

A	B	C	D	E
205	130	3	240	200

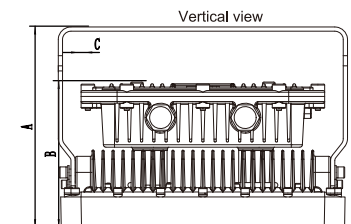
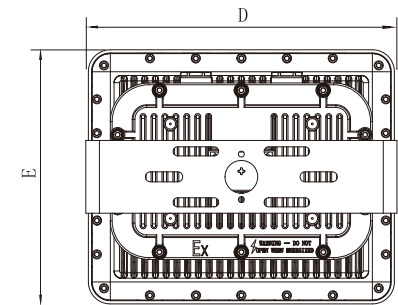

Measuring Unit: mm

Hazloc LED Luminaire

A: Ceiling Type

1. According to the bracket hole distance, installed two M10 bolts on the roof
2. Tighten the bracket from two sides to wrench tight.
3. Bolt the universal mounting bracket and tighten the M10 bolts to the field mounting point.
4. Wiring. (Connect supply wires to luminaire wire leads per the wiring diagram using methods that comply with all applicable codes.)

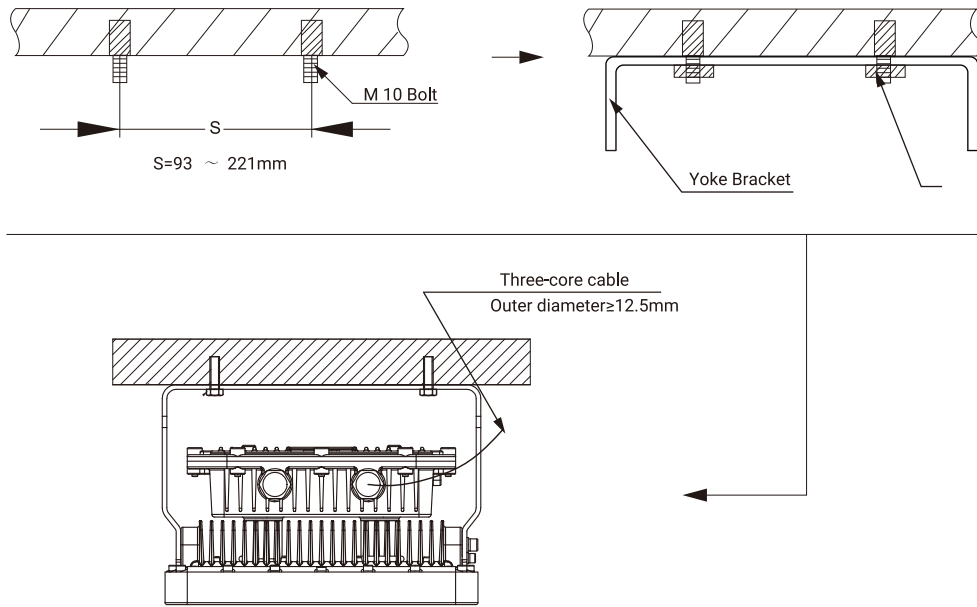

Hazloc LED Luminaire

B: Wall Type

1. According to the bracket hole distance, installed two M10 bolts on the side wall;
2. Tighten the bracket from two sides to wrench tight.
3. Bolt the universal mounting bracket and tighten the M10 bolts to the field mounting point.
4. Wiring. (Connect supply wires to luminaire wire leads per the wiring diagram using methods that comply with all applicable codes.)

