

Crane Master Series LED Luminaire

General Wiring Diagram

CAUTION: Turn off electrical power at fuse or circuit breaker box before wiring fixture to the power supply.

Connecting panels to AC source supply:
All units must be individually connected to the AC supply.

- Blue = ACN
- Brown = ACL
- Green/Yellow = ⊕

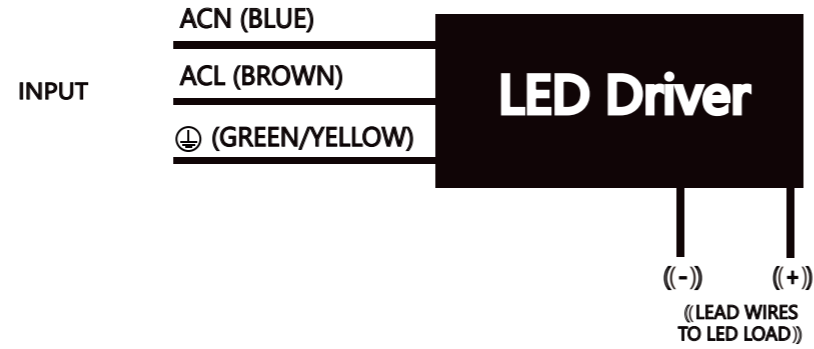

Product Dimension

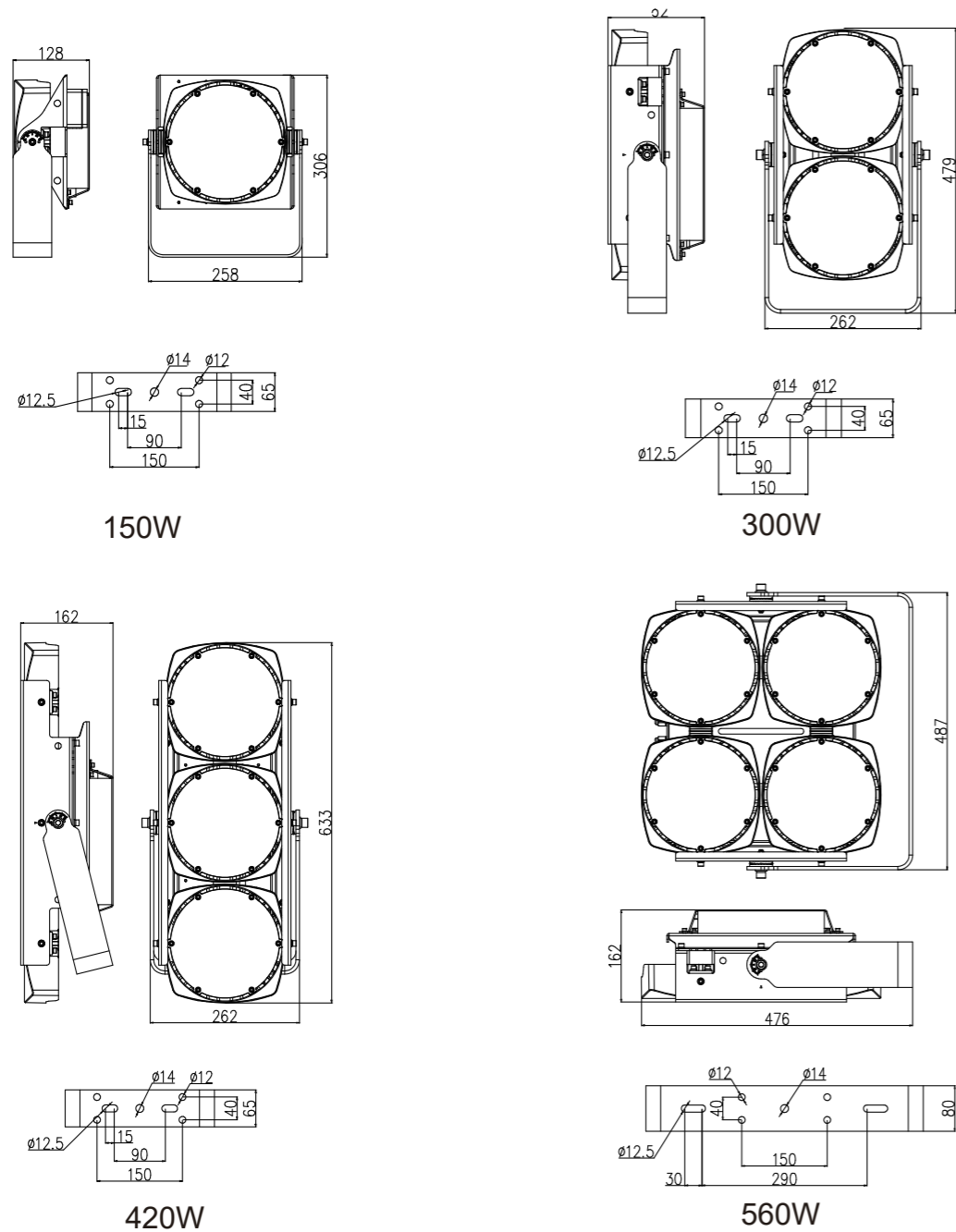

Installation & Operation

1. Secure the bracket to the wall or equipment beam using M10 bolts.
2. Open the junction box to wire.
3. Adjust the angle of the luminaire bracket and tighten the M10 hex bolts on the bracket to fix it.

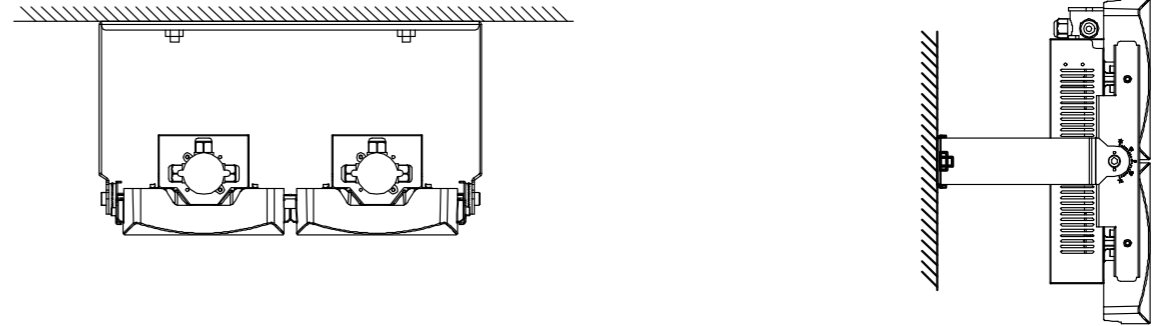

Crane Master Series LED Luminaire

Servicing

- To avoid personal injury, disconnect power to the light and allow the unit to cool down before performing maintenance.
- Perform visual, electrical, and mechanical inspections on a regular basis. The environment and frequency of use should determine this. However, it is recommended that checks should be made at least once a year. Frequency of use and environment should determine this.
- The external lens should be cleaned periodically to ensure continued luminaire performance. Clean the lens with a clean, damp, non-abrasive, lint-free cloth. If this is not sufficient, use a mild soap or a liquid cleaner. Do not use an abrasive, strong alkaline or acid cleaner as damage may occur. Organic solvent is absolutely forbidden to soak the lens.
- Inspect the cooling fins on the luminaire to ensure that they are free of any contamination (i.e. excessive dust build-up). Clean with a non-abrasive cloth if needed.
- Mechanically check to make sure all parts are properly assembled.
- Electrically check to make sure that all connections are clean and tight.

Housing

- Shell surface of electrostatic spraying, Long lasting and Durable
- Shell protection, Over-voltage and Over-heat protection
- Exposed fasteners with quality stainless steel
- Excellent anti-corrosive property

Crane Master Series LED Luminaire

Warranty

We warrant that each of our LED lighting luminaire (the "Product(s)") that are purchased while this Warranty is in effect will be free from defects in materials and workmanship for the period of time specified in the table below (the "Warranty Period"). The Warranty Period runs from the date of original purchase from its authorized distributor/dealer.

We will repair, or at our option, replace the defective product (exterior finish, housing and heat sinks, lens, LED engine, power supply) during the standard warranty period. This warranty applies only to the repair or replacement of the product and only when the product is properly handled, installed and maintained according to our instructions.

This warranty excludes defects resulting from improper installation, acts of God, fire, vandalism or civil disturbances, power surges or improper power supply, and corrosive environment installations.

This warranty does not cover equipment, systems or components from other manufacturers that the Purchaser uses in conjunction with the Product. Any repair, alteration or modification of the Product, including replacement of Product components with components of other manufacturers will void the warranty in its entirety.

LED Product	Models Cover By Warranty	Warranty Period
Crane Master Series LED Luminaire	CMF-XXX	Five(5) Years

Crane Master Series LED Luminaire

General Safety Information

- To reduce the risk of death, personal injury or property damage from fire, electric shock, falling parts, cuts/abrasions and other hazards, please read all warnings and instructions included with and on the fixture box and all fixture labels.
- Before installing, servicing, or performing routine maintenance upon this equipment, please follow these general precautions.
- Commercial installation, service and maintenance of luminaires should be performed by a qualified licensed electrician.
- **DO NOT INSTALL DAMAGED PRODUCT!**
- This fixture is intended to be connected to a properly installed and grounded UL listed junction box.
- Make sure that the supply voltage is the same as the luminaire voltage.
- Do not install where the marked operating temperatures exceed the ignition temperatures of the hazardous atmosphere.
- Do not operate in ambient temperatures above those indicated on the luminaire nameplate.
- All gasket seals must be clean and undamaged.

WARNING:

RISK OF ELECTRICAL SHOCK

- Turn off electrical power at fuse or circuit breaker box before wiring fixture to the power supply.
- Turn off the power when you perform any maintenance.
- Verify that supply voltage is correct by comparing it with the luminaire label information.
- Make all electrical and grounded connections in accordance with the National Electrical Code and any applicable local code requirements.
- All wiring connections should be capped with UL approved wire connectors.
- Luminaire must be supplied by a wiring system with an equipment grounding conductor.

CAUTION:

RISK OF INJURY

- Wear gloves and safety glasses at all times when removing luminaire from carton, installing, servicing or performing maintenance.
- Avoid direct eye exposure to the light source while it is on.
- Account for small parts and destroy packing material, as these may be hazardous to children.

CAUTION:

RISK OF FIRE

- Keep combustible and other materials that can burn away from luminaire and lamp/lens.
- **MIN 90°C SUPPLY CONDUCTORS.**

MODELS:

CMF-2-3-4-5-6-7-8

2 – Wattage 150 - 150W, 300 - 300W, 420 - 420W, 560 - 560W

3 – Voltage 100-240V AC

4 – Color Temperature 57K - 5700K, 5K - 5000K, 4K - 4000K, 3K - 3000K

5 – Beam Angle 30 - 30°, 60 - 60°, 90 - 90°, 120 - 120°, 32-30*120°

6 – Lens CG - Clear Glass, CP - Clear PC

7 – Finish Color GRY – Grey

8 – Mounting YKE - Yoke

* Glass Lens: Only available for 120°

** PC Lens: Only available for 30°/60°/90°/30*120°

Ambient temperature -40°C ~ +50°C

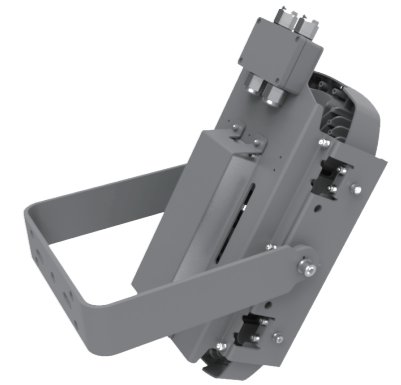

Picture is for illustration purposes only. Your model may vary